

edbak

WE ARE THE SOLUTION



FULL LINE CATALOGUE

2018

INNOVATIVE INSTALLATION SOLUTIONS
FOR VIDEO DISPLAYS

• COMPANY



We have been present and constantly developing on the ProAV market since 1992 to keep up with your needs. Over the years, we have been expanding our portfolio, which now includes all products necessary for professional AV installations. Our globally acclaimed solutions have been designed, tested and produced by top-tier professionals. We are present in the largest markets and continue to implement prestigious projects together with our customers. We are happy that through hard work and dedication we have been able to build trust and expand our partner base even further.

Our catalogue presents a number of new products to meet our partners' requirements. Modular video walls, structures for LED modules, videoconferencing trolleys, wall mounts and projector mounts have received a new design and features. With the option to deliver customised products, we provide you with even more opportunities.

See the new product catalogue and visit www.edbakproav.com for full information on our offer.

Edward Bæk
President of the Board



● KEY FEATURES AND ADVANTAGES

● NEW SOLUTIONS

We are always seeking to fulfil changing market requirements. In order to achieve the best solutions, we started **producing our components from aluminium**. Such new materials bring new possibilities: modern design, lighter weight and recyclability.



● **VSM** - Swing Arm Wall Mount Series



● **VWSA** - Video Wall Stand



● **TRV** - Video Conferencing Trolley's



● **WPMV** - Wall Projector Mount

● NEW MARKET

We have successively entered a new and global market. The quality of our products and the high standards of our customer service and technical support allow us to sell our products in the USA and EMEA countries. **In 2017 we began selling Edbak products in the UK.**

● INVESTMENT

In last year we **invested more than 3 million EURO** in new machines and R&D. This gives us the full technological potential to manufacture complex parts followed by precision machining.

● QUALITY

At Edbak we have introduced the latest in automated machine technologies and techniques to our **ISO 9001 certified facilities**, ensuring improved speed and precision whilst retaining the **TUV certified product quality**. The in-house product development and engineering staff ensure we retain the ability to meet the needs of and fabricate the parts for multiple vertical markets.



● TECHNOLOGY & OWN PRODUCTION

Our production facilities are located in Piotrowice, in south-east Poland. The modern production facilities and qualified staff allow us to implement new technologies. We also have our own engineering centre, where we design new solutions and functionalities. **We design, test and produce all products in our facilities located in Poland.**

● BUSIENSS PARTNER PORTAL

We have designed and developed an automated B2B support portal, to give our partners access to such vital information as order status, current inventory levels, account balance, delivery notes, invoices, marketing database and technical support, **all available when it is needed, 24/7.**

● SALES MAP

● NORTH AMERICA

USA

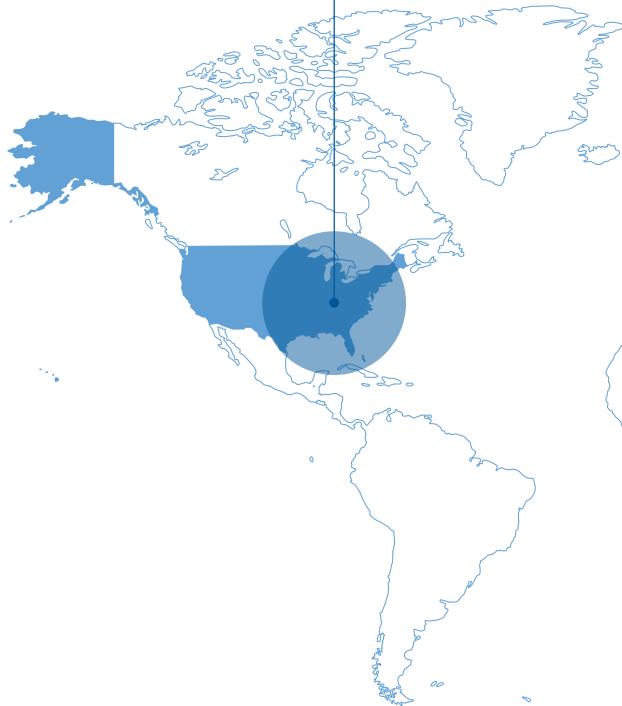

● EUROPE

Austria, Belgium, Czech Republic, Cyprus, Denmark, Estonia, Finland, France, Germany, Greece, Hungary, Ireland, Italy, Latvia, Lithuania, Luxembourg, Malta, Netherlands, Norway, Portugal, Romania, Serbia, Slovakia, Spain, Sweden, Switzerland, United Kingdom

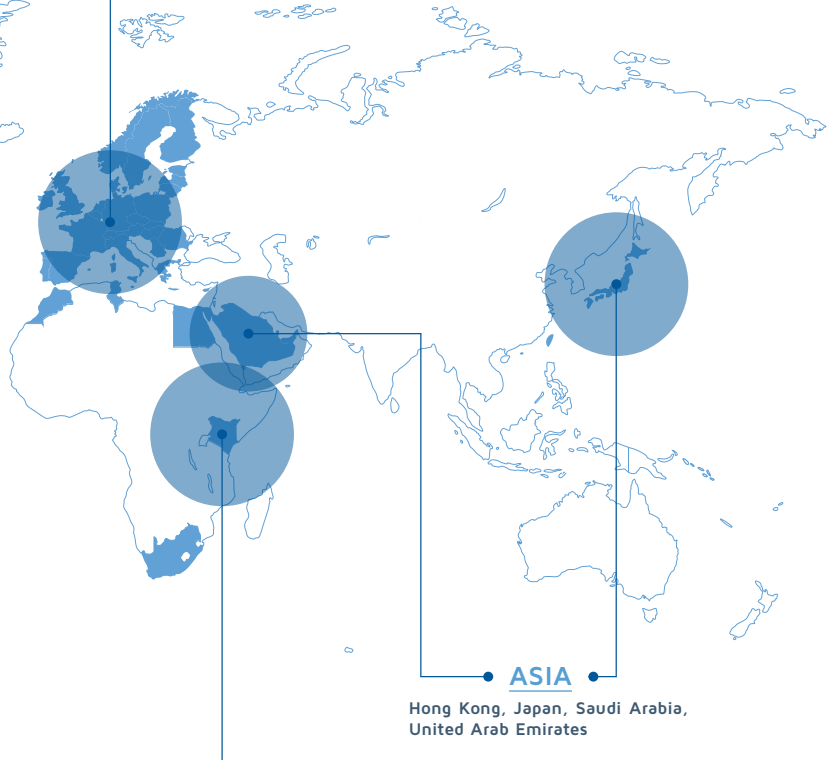

● ASIA

Hong Kong, Japan, Saudi Arabia, United Arab Emirates

● AFRICA

Egypt, Kenya, Morocco, Qatar, Republic of South Africa, Tunisia

2017



FEB

AMSTERDAM (NETHERLANDS)

Integrated
Systems
Europe

ISE is the world's largest AV systems integration event. It showcases the latest cutting-edge technology, products and solutions being produced for both channel and end-user professionals.



MAR

KIELCE (POLAND)

AB PL
DIGITAL WORLD

Możliwości i Rozwój – This conference demonstrates the possibilities in business strategy and product development. Edbak takes part in this event with its partner – Samsung.



JUL

MONACHIUM (GERMANY)

digital
signage
summit
europe

Digital Signage Summit Europe (DSS) is Europe's leading strategy conference for the Digital Signage and Digital Out of Home industry.



OCT

WIELICZKA (POLAND)

NEC Competence Days









NEC Competence Days-ProAV Solutions is the biggest AV event in Poland. It consists of two elements: a conference and an AV innovative products exhibition.

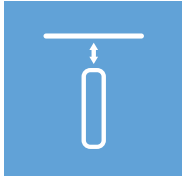
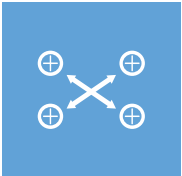

TABLE OF CONTENTS

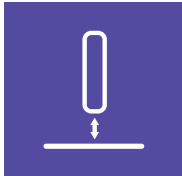
PROJECTOR MOUNTS	19
TROLLEYS AND STANDS	27
VIDEO WALLS	47
FLAT PANEL WALL MOUNTS	69
MENU BOARDS	87
MONITOR MOUNTS	95
CABLE CUBBIES	115
POS MOUNTS	121
TABLETS	125
INFOKIOSKS AND ENCLOSURES	131

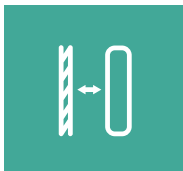
ICONS MAP

	Screen Size		Swivel		Distance from Ceiling
	Mounting Pattern		Tilt		Height Adjustment
	Maximum Load		Distance from Wall		Landscape to Portrait

PROJECTOR MOUNTS

► Ceiling

Product	Image	Adjustment range	Max. capacity	Extension range	Colour	Dimensions (HxWxD)	Page
PM1 Universal Projector Ceiling Mount (3 fixing points)		90° / 90°	15 kg	448-656 mm	black silver white	656x450x450 mm	20
PM2 Universal Projector Ceiling Mount (4 fixing points)		90° / 90°	15 kg	448-656 mm	black silver white	656x480x480 mm	20
PM3 Universal Projector Ceiling Mount (3 fixing points)		90° / 90°	15 kg	250-300 mm	black silver white	300x420x420 mm	21
PM4 Universal Projector Ceiling Mount		90° / 90°	15 kg	110 mm	black silver white	110x450x450 mm	21
PM8 Universal Projector Ceiling Mount		7,5° / 7,5°	20 kg	740-1100 mm	black silver white	670x240x80 mm	22
PM8.1 Universal Projector Ceiling Mount		7,5° / 7,5°	20 kg	540-740 mm	black silver white	1100 x 545 x 545 mm	22
PM8.2 Universal Projector Ceiling Mount		7,5° / 7,5°	20 kg	1100-1900 mm	black silver white	1100 x 545 x 545 mm	22
PM8.3 Universal Projector Ceiling Mount		7,5° / 7,5°	20 kg	270 mm	black silver white	670x240x80 mm	22
PMV100 Projector Ceiling Mount		+15°/-15°	15 kg	450-650 mm	black silver white	450x180x180 mm	24
PMV200 Projector Ceiling Mount		+15°/-15°	15 kg	650-1000 mm	black silver white	650x180x180 mm	24
PMV300 Projector Ceiling Mount		+15°/-15°	15 kg	1000-1700 mm	black silver white	1000x180x180 mm	24





















► Projector Short Throw Wall Mounts









Product	Image	Adjustment range	Max. capacity	Extension range	Colour	Dimensions (HxWxD)	Page
WPM1 Universal Projector Wall Mount (3 fixing points)		+7,5° / -7,5°	15 kg	800-1293 mm	black silver white	1293x236x545 mm	23
WPMV100 Projector Wall Mount		+15°/-15°	15 kg	500-800 mm	black silver white	590x250x180 mm	25
WPMV200 Projector Wall Mount		+15°/-15°	15 kg	800-1300 mm	black silver white	890x250x180 mm	25

► Trolleys







Product	Image	Adjustment range	Max. capacity	Extension range	Colour	Dimensions (HxWxD)	Page
PT03 Projector Trolley		5° / 15°	15 kg	800-1293 mm	black	510x460x810 mm	23



TROLLEYS AND STANDS





Product	Image	Screen size	VESA (mm)	Max. capacity	Height adjustment	Tilt	Dimensions (HxWxD)	Page
STD16 32"-47" Display Stand		32"-47"	min. 75x95 max. 600x400	30 kg	min. 300 mm max. 1600 mm	-6,5°/+12°	1720x800x570 mm	28
STD17D 37"-60" Stand and Trolley for 2 displays		37"-60"	min. 75x95 max. 600x400	50 kg	min. 300 mm max. 1600 mm	-6°/+9°	1750x1200x740 mm	28
STD17 37"-60" Display Stand and Trolley		37"-60"	min. 75x95 max. 600x400	50 kg	min. 300 mm max. 1600 mm	-6°/+9°	1750x1200x740 mm	29
STD25 42"-50" Display Stand with Enclosure		42"-50"	min. 400x400 max. 600x400	71 kg	min. 2000 mm max. 2330 mm	nd	2285x700x370 mm	30
TR1 42"-70" Flat Screen Trolley		42"-70"	min. 75x75 max. 600x400	80 kg	min. 300 mm max. 1700 mm	-6°/+9°	1125x700x1780 mm	30
STD01 32"-55" Display Stand		32"-55"	min. 75x75 max. 600x400	80 kg	min. 310 mm max. 1700 mm	nd	1700 x800x350 mm	31
STD04 19"-32" Display Stand		19"-32"	min. 75x75 max. 100x100	15 kg	1048,5 mm	0°/+45°	1048,5x559x350 mm	32
TRV100 42"-55" Video Conferencing Trolley		42"-55"	min. 100x100 max. 600x400	70 kg	min. 300 mm max. 1700 mm	0°/+11°	1850x1050x900 mm	33
TRV200 60"-75" Video Conferencing Trolley		60"-75"	min. 100x100 max. 800x400	120 kg	min. 300 mm max. 1700 mm	0°/+11°	1850x1250x900 mm	33
TRV300 42"-55" Video Conferencing Trolley for 2 Displays		42"-55"	min. 100x100 max. 600x400	120 kg	min. 300 mm max. 1700 mm	0°/+11°	1850x1960x900 mm	34
TR3 37"-60" Dual Displays AV Trolley		37"-60"	min. 75x75 max. 600x400	80 kg	min. 200 mm max. 2000 mm	-6°/+9°	2083x1116x802 mm	35
TR51 37"-60" Displays AV Trolley		37"-60"	min. 75x75 max. 400x400	80 kg	min. 520 mm max. 1700 mm	-6°/+9°	1700x1140x703 mm	35
TR5 32"-60" Flat Screen AV Trolley		32"-60"	min. 75x75 max. 600x400	80 kg	min. 250 mm max. 1700 mm	-6°/+9°	1150x700x1770 mm	36
TR7 37"-60" Flat Screen AV Trolley		37"-60"	min. 75x75 max. 600x400	80 kg	1606 mm	nd	1006x1070x500 mm	37
TR8 37"-60" Low Level Flat Screen Trolley		37"-60"	min. 75x75 max. 600x400	80 kg	1606 mm	nd	1006x1070x500 mm	37
SV53 19"-27" Universal Adjustable Trolley with PC Mount		19"-27"	min. 75x75 max. 100x100	10 kg	1270 mm	250°	1270x690x690 mm	38
TR14 40"-47" Dual Flat Screen AV Trolley		40"-47"	min. 100x100 max. 600x400	80 kg	min. 300 mm max. 1600 mm	nd	1850x1800x815 mm	38
TR18 60"-95" Flat Screen AV Trolley		60"-95"	min. 75x75 max. 600x400	80 kg	min. 300 mm max. 1700 mm	nd	1869x1705x815 mm	39
TR20 50"-60" Dual Flat Screen AV Trolley		50"-60"	min. 75x75 max. 600x400	80 kg	min. 300 mm max. 1700 mm	nd	1874x2200x815 mm	39
ETR3 40"-55" Electric height-adjustable AV Trolley		40"-55"	min. 100x100 max. 600x400	60 kg	min. 100x100 mm max. 600x400 mm	0°/90°	1200x900x750 mm	40

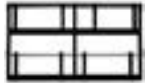
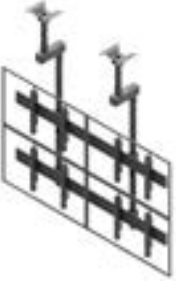





Product	Image	Screen size	VESA (mm)	Max. capacity	Height adjustment	Tilt	Dimensions (HxWxD)	Page
ETR4 60"-95" Electric height-adjustable AV Trolley		60"-95"	min. 100x100 max. 600x400	60 kg	min. 200x100 mm max. 600x400 mm	0°/90°	1450x900x750 mm	40
ETRE3 40"-55" Electric height-adjustable AV trolley		40"-55"	min. 100x100 max. 400x200	60 kg	min. 825 mm max. 1657 mm	0°/90°	1200x900x750 mm	40
ETRE4 60"-95" Electric height-adjustable AV trolley		60"-95"	min. 100x100 max. 800x400	80 kg	min. 825 mm max. 1500 mm	0°/90°	1382x1500x723 mm	40
VCTX170 42"-70" Video Conferencing Trolley with height adjustment		42"-70"	min. 100x100 max. 800x400	97 kg	min. 1000 mm max. 1800 mm	nd	1100x1958x873 mm	41
VCTX190 79"-90" Video Conferencing Trolley with height adjustment		79"-90"	min. 100x100 max. 800x400	100 kg	min. 1000 mm max. 1800 mm	nd	1100x1958x873 mm	41
VCTR260 50"-60" VCTR Series Video Conferencing Trolley for 2 Screens		50"-60"	min. 75x75 max. 600x400	80 kg	min. 300 mm max. 1700 mm	nd	1874x2200x815 mm	41
VCTX247 40"-47" Video Conferencing Trolley for 2 Screens		40"-47"	min. 100x100 max. 600x400	80 kg	min. 1000 mm max. 1800 mm	nd	1900x1958x873 mm	42
VCTX255 50"-55" Video Conferencing Trolley for 2 Screens		50"-55"	min. 200x100 max. 600x400	80 kg	min. 1000 mm max. 1800 mm	nd	1900x1958x873 mm	42
VCTR195 65"-95" Video Conferencing Trolley		65"-95"	min. 100x100 max. 1000x600	80 kg	min. 1030mm max. 1850 mm	nd	1845x1705x878 mm	43

VIDEO WALLS

Product	Image	Screen size	VESA (mm)	Max. capacity	Height adjustment	Tilt	Dimensions (HxWxD)	Page
VWPOP Series VWPOP65-L Quick Release Pop-Out Universal Video Wall Mount		42"-85"	max. 600x400 mm	60 kg	85-270 mm	-0/+28°	824x530x80 mm	49
		70"-95"	max. 800x600 mm	130 kg	85-270 mm	-0/+28°	1084x700x100 mm	49
VWFS Series VWFS65-L Full Service Universal Video Wall		42"-85"	max. 600x400 mm	60 kg	85-270 mm	-0/+28°	824x500x80 mm	50
		90"-95"	max. 800-600 mm	130 kg	85-270 mm	-0/+28°	1070x670x100 mm	50
VWFX Series VWFX65-L Fixed Universal Video Wall Mount Landscape		42"-85"	max. 600-400 mm	60 kg	7,5 mm	nd	826x500x80 mm	51
		90"-95"	max. 800-600 mm	130 kg	7,5 mm	nd	1076x670x100 mm	51
VWPOP Series VWPOP65-P Quick Release Pop-Out Universal Video Wall Mount		42"-85"	max. 400-600 mm	60 kg	85-270 mm	-0/+28°	512x530x80 mm	53
		90"-95"	max. 600-600 mm	130 kg	85-270 mm	-0/+28°	876x670x100 mm	53
VWFS Series VWFS65-P Full Service Universal Video Wall		42"-85"	max. 400-600 mm	60 kg	85-270 mm	-0/+28°	512 x 500 x 80 mm	54
		90"-95"	max. 600-600 mm	130 kg	85-270 mm	-0/+28°	876 x 670 x 100 mm	54
VWFX Series VWFX65-P Fixed Universal Video Wall Mount, Portrait		42"-85"	max. 400-300 mm	60 kg	85-270 mm	nd	500x514x80 mm	55
		90"-95"	max. 600-600 mm	130 kg	85-270 mm	nd	670x876x100 mm	55

Product		Image	Screen size	VESA (mm)	Max. capacity	Height adjustment	Tilt	Dimensions (HxWxD)	Page
	VWV2255POP-L Video Wall pop-out for 4 screens 50"-55"		50"-55"	min. 100x100 max. 400x600 mm	200 kg	min. 100 x 100 max. 600 x 400 mm	nd	2100x1210x100 mm	56
VWCA Landscape Series	VWCA2247-L Ceiling Video Walls		42"-47"	min. 100x100 max. 600x400 mm	130 kg	100-1300 mm	nd	2200x1960x370 mm	57
	VWCA2257-L Ceiling Video Walls		50"-57"	min. 100 x 100 max. 600 x 400 mm	125 kg	100-1300 mm	nd	2200x2220x370 mm	57
	VWCA3247-L Ceiling Video Walls		42"-47"	min. 100 x 100 max. 600 x 400 mm	200 kg	100-1300 mm	nd	2200x2930x370 mm	57
	VWCA3257-L Ceiling Video Walls		50"-57"	min. 100 x 100 max. 600 x 400 mm	195 kg	100-1300 mm	nd	2200x3320x370 mm	57
	VWCA3347-L Ceiling Video Walls		42"-47"	min. 100 x 100 max. 600 x 400 mm	120 kg	100-1900 mm	nd	2600x2930x370 mm	57
	VWCA3357-L Ceiling Video Walls		50"-57"	min. 100 x 100 max. 600 x 400 mm	125 kg	100-1900 mm	nd	2600x3320x370 mm	57
	VWCA2347-L Ceiling Video Walls		42"-47"	min. 100 x 100 max. 600 x 400 mm	90 kg	100-1900 mm	nd	2600x1960x370 mm	57
	VWCA2357-L Ceiling Video Walls		50"-57"	min. 100 x 100 max. 600 x 400 mm	95 kg	100-1900 mm	nd	2600x2220x370 mm	57
VWTA Landscape Series	VWTA2247-L Trolley Video Walls		42"-47"	min. 100 x 100 max. 600 x 400 mm	220 kg	100-1300 mm	nd	1970x1960x950 mm	58
	VWTA2257-L Trolley Video Walls		50"-57"	min. 100 x 100 max. 600 x 400 mm	210 kg	100-1300 mm	nd	1970x2220x950 mm	58
	VWTA2347L Trolley Video Walls		42"-47"	min. 100 x 100 max. 600 x 400 mm	205 kg	100-1900 mm	nd	2570x1960x950 mm	58
	VWTA2357-L Trolley Video Walls		50"-57"	min. 100 x 100 max. 600 x 400 mm	190 kg	100-1900 mm	nd	2570x2220x950 mm	58
	VWTA3247-P Trolley Video Walls		42"-47"	min. 100 x 100 max. 600 x 400 mm	205 kg	100-1300 mm	nd	2550x820x950 mm	58
	VWTA3257-L Trolley Video Walls		50"-57"	min. 100 x 100 max. 600 x 400 mm	290 kg	100-1300 mm	nd	1970x3320x950 mm	58
	VWTA3347-L Trolley Video Walls		42"-47"	min. 100 x 100 max. 600 x 400 mm	305 kg	100-1900 mm	nd	2570x2930x950 mm	58
	VWTA3357-L Trolley Video Walls		50"-57"	min. 100 x 100 max. 600 x 400 mm	290 kg	100-1900 mm	nd	2570x3320x950 mm	58
VWSA Landscape Series	VWSA2247-L Video Wall Stand		42"-47"	max. 400-300 mm	220 kg	85-270 mm	nd	1830x1960x350 mm	60
	VWSA2257-L Video Wall Stand		50"-57"	max. 600-400 mm	210 kg	85-270 mm	nd	1830x2220x350 mm	60
	VWSA2347-L Video Wall Stand		42"-47"	max. 100-600 mm	205 kg	100-1900 mm	nd	2430x1960x350 mm	60
	VWSA2357-L Video Wall Stand		50"-57"	max. 100-600 mm	190 kg	100-1900 mm	nd	2430x2220x350 mm	60
	VWSA3247-L Video Wall Stand		42"-47"	max. 100-600 mm	305 kg	100-1300 mm	nd	1830x2930x350 mm	60
	VWSA3257-L Video Wall Stand		50"-57"	max. 100-600 mm	290 kg	100-1300 mm	nd	1830x3320x350 mm	60
	VWSA3347-L Video Wall Stand		42"-47"	max. 100-600 mm	305 kg	100-1900 mm	nd	2430x2930x350 mm	60
	VWSA3357-L Video Wall Stand		50"-57"	max. 100-600 mm	290 kg	100-1900 mm	nd	2430x3320x350 mm	60

Product		Image	Screen size	VESA (mm)	Max. capacity	Height adjustment	Tilt	Dimensions (HxWxD)	Page
VWFA Landscape Series	VWFA2247-L Video Wall Ceiling - Floor Mounted		42"-47"	max. 100-600 mm	220 kg	100-1300 mm	nd	4000x1960x270 mm	61
	VWFA2257-L Video Wall Ceiling - Floor Mounted		50"-57"	max. 100-600 mm	210 kg	100-1300 mm	nd	4000x2220x270 mm	61
	VWFA2347-L Video Wall Ceiling - Floor Mounted		42"-47"	max. 100-600 mm	220 kg	100-1900 mm	nd	4000x1960x270 mm	61
	VWFA2357-L Video Wall Ceiling - Floor Mounted		50"-57"	max. 100-600 mm	210 kg	100-1900 mm	nd	4000x2220x270 mm	61
	VWFA3247-L Video Wall Ceiling - Floor Mounted		42"-47"	max. 100-600 mm	210 kg	100-1300 mm	nd	4000x2930x270 mm	61
	VWFA3257-L Video Wall Ceiling - Floor Mounted		50"-57"	max. 100-600 mm	330 kg	100-1300 mm	nd	4000x3320x270 mm	61
	VWFA3347-L Video Wall Ceiling - Floor Mounted		42"-47"	max. 100-600 mm	330 kg	100-1900 mm	nd	4000x2930x270 mm	61
	VWFA3357-L Video Wall Ceiling - Floor Mounted		50"-57"	max. 100-600 mm	310 kg	100-1300 mm	nd	4000x3320x270 mm	61
VWCA Portrait Series	VWCA2247-P Ceiling Video Walls		42"-47"	max. 100-600 mm	95 kg	100-1300 mm	nd	2700x1220x370 mm	62
	VWCA2257-P Ceiling Video Walls		50"-57"	max. 100-600 mm	90 kg	100-1300 mm	nd	2700x1420x370 mm	62
	VWCA2347-P Ceiling Video Walls		42"-47"	max. 100-600 mm	110 kg	100-1900 mm	nd	2600x1960x370 mm	62
	VWCA2357-P Ceiling Video Walls		49"-55"	max. 100-600 mm	105 kg	100-1900 mm	nd	2600x2220x370 mm	62
VWTA Portrait Series	VWTA2247-P Trolley Video Walls		42"-47"	max. 100-600 mm	220 kg	100-1300 mm	nd	2550x1220x950 mm	63
	VWTA2257-P Trolley Video Walls		50"-57"	max. 100-600 mm	210 kg	100-1300 mm	nd	2550x1420x950 mm	63
	VWTA3247-P Trolley Video Walls		42"-47"	max. 100-600 mm	205 kg	100-1900 mm	nd	2550x820x950 mm	63
	VWTA3257-P Trolley Video Walls		50"-57"	max. 100-600 mm	190 kg	100-1900 mm	nd	2550x2120x950 mm	63
VWSA Portrait Series	VWSA2247-P Video Wall Stand		42"-47"	max. 100-600 mm	220 kg	100-1300 mm	nd	2430x1220x350 mm	64
	VWSA2257-P Video Wall Stand		50"-57"	max. 100-600 mm	210 kg	100-1300 mm	nd	2430x1420x350 mm	64
	VWSA2347-P Video Wall Stand		42"-47"	max. 100-600 mm	205 kg	100 - 1300 mm	nd	2550x1800x900 mm	64
	VWSA2357-P Video Wall Stand		50"-57"	max. 100-600 mm	190 kg	100-1900 mm	nd	2430x2120x300 mm	64
VWFA Portrait Series	VWFA2247-P Video Wall Ceiling-Floor Mounted		42"-47"	max. 100-600 mm	220 kg	100-600 mm	nd	4000x1220x270 mm	65
	VWFA2257-P Video Wall Ceiling-Floor Mounted		50"-57"	max. 100-600 mm	210 kg	100-600 mm	nd	4000x1420x270 mm	65
	VWFA3247-P Video Wall Ceiling-Floor Mounted		42"-47"	max. 100-600 mm	330 kg	100-600 mm	nd	4000x1800x270 mm	65
	VWFA3257-P Video Wall Ceiling-Floor Mounted		50"-57"	max. 100-600 mm	310 kg	100-600 mm	nd	4000x2100x300 mm	65

Product	Image	Screen size	VESA (mm)	Max. capacity	Height adjustment	Tilt	Dimensions (HxWxD)	Page
VWLT100 Mobile LED Mounting System								66
VWLCF100 Floor-Ceiling LED Mounting System								66
VWLC100 Ceiling LED Mounting System								67
VWLS100 Stand LED Mounting System								67
VWLW100 Pop-Out Led Video Wall Mounting System								68
VWLWE100 Electric Pop-Out Led Video Wall Mounting System								68





Led Mounting system offers a multiple monitor mounts to support your LED screen configuration needs on a wall mounted, ceiling mounted or floor based custom display stand.
Just about any custom configuration can be designed and engineered for your specific needs.

FLAT PANEL WALL MOUNTS











► Thin Swing Arm Wall Mounts / Swing Arm Wall Mounts / Heavy Duty Swing Arms

Product	Image	Screen size	Max. capacity	VESA (mm)	Height adjustment	Tilt	Dimensions (HxWxD)	Page
PWS2 32"-50" Swing Arm Wall Mount		32"-50"	25 kg	min. 200x200 max. 600x400	0°/+10°	62-638 mm	638x660x440 mm	70
VSM651 10"-29" Swing Arm Wall Mount		10"-29"	12 kg	min. 75x75 max. 100x100	+60°/-60°	230-415 mm	120x170x415 mm	71
VSM652 30"-47" Swing Arm Wall Mount		30"-47"	36 kg	min. 100x100 max. 600x400	-0°/+11°	105-405 mm	455x720x405 mm	71
VSM653 30"-47" Swing Arm Wall Mount		30"-47"	36 kg	min. 100x100 max. 600x400	-0°/+11°	100-700 mm	455x720x700 mm	72
VSM654 37"-65" Swing Arm Wall Mount		37"-65"	45 kg	min. 100x100 max. 600x400	-0°/+11°	100-700 mm	455x720x700 mm	73
RPWS1 42"-70" Heavy Duty Swing Arm Wall Mount		42"-70"	120 kg	min. 100x100 max. 600x400	-10°/+10°	min. 150mm max. 800 mm	800x980x520 mm	73
RMSA1 42"-90" Heavy Duty Swing Arm Wall Mount		42"-90"	120 kg	min. 100x100 max. 600x400	-10°/+10°	min. 150 mm max. 700 mm	700x850x520 mm	74





► Super Slim Fixed Wall Mounts / Fixed Wall Mounts / Tilting Wall Mounts / Wall Mounting System

Product	Image	Screen size	Max. capacity	VESA (mm)	Adjustment possibility	Extension	Dimensions (HxWxD)	Page
EWB100 26"-40" Fixed Wall Mount		26"-40"	40 kg	min. 60x65 max. 440x337,5	25,5 mm	nd	495x370x25,5 mm	75
EWB200 40"-65" Fixed Wall Mount		40"-65"	40 kg	min. 60x65 mm max. 825x427,5	25,5 mm	nd	850x470x25,5 mm	75
LWB1 26"-42" Fixed Wall Mount		26"-42"	60 kg	min. 100x100 max. 400x300	40 mm	nd	540 x 260 x 41 mm	76
LWB3 26"-40" Portrait Wall Mount		26"-40"	60 kg	min. 100x100 max. 400x300	41 mm	nd	350x490x41 mm	76



► Super Slim Fixed Wall Mounts / Fixed Wall Mounts / Tilting Wall Mounts / Wall Mounting System

Product	Image	Screen size	Max. capacity	VESA (mm)	Adjustment possibility	Extension	Dimensions (HxWxD)	Page
PWB1 42"-55" Fixed Wall Mount		42"-55"	80 kg	min. 100x100 max. 600x400	40 mm	nd	800 x 500 x 41 mm	77
PWB3 42"-60" Portrait Wall Mount		42"-60"	80 kg	min. 100x100 max. 600x400	45 mm	nd	458 x 780 x 44,6 mm	77
TWB1 65"-75" Fixed Wall Mount		65"-75"	80kg	min. 100x100 max. 800x400	40 mm	nd	900 x 500 x 48,5 mm	78
TWB3 65"-75" Portrait Wall Mount		65"-75"	80 kg	min. 100x100 max. 800x400	456 mm	nd	550 x 950 x 44,6 mm	78
XWB1 80"-95" Fixed Wall Mount		80"-95"	110 kg	min. 200x200 max. 1200x600	42 mm	nd	1260x540x42 mm	79
XWB3 80"-95" Portrait Wall Mount		80"-95"	80 kg	min. 100x200 max. 1200x400	41 mm	nd	600 x 1245 x 41 mm	79
EWB250 40"-65" Tilt Wall Mount		40"-65"	40 kg	min. 100x100 max. 800x400	48,75 mm	0°/+12°	850 x 470 x 48,75 mm	80
LWB2 26"-40" Tilt Wall Mount		26"-40"	60 kg	min. 100x100 max. 400x300	75,33 mm	-6°/+12°	540 x 300 x 41 mm	80
PWB2 42"-60" Tilt Wall Mount		42"-60"	80 kg	min. 100x100 max. 600x400	77,4 mm	-6°/+12°	805x220x88 mm	81
TWB2 60"-75" Tilt Wall Mount		60"-75"	80 kg	min. 100x100 max. 800x400	77,4 mm	-6°/+11°	910 x 220 x 75 mm	82

















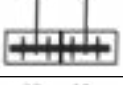
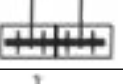

► Flat Screen Ceiling Mounts

Product	Image	Screen size	Max. capacity	VESA (mm)	Adjustment possibility	Extension	Dimensions (HxWxD)	Page
CMLS2 32"-47" Tilt Ceiling Mount		32"-47"	30 kg	min. 100x100 max. 600x400	-0°/+22°	min. 1332 mm max. 1770 mm	1170 x 800 x 183 mm	82
CMS21 37"-65" Adjustable Ceiling Mount		37"-65"	60 kg	min. 100x100 max. 600x400	-12,5°/+6,5°	min. 1775 mm max. 2575 mm	2175 x 800 x 200 mm	83
CMS1 32"-65" LCD Ceiling Mount		32"-65"	60 kg	min. 100x100 max. 600x400	-12,5°/+6,5°	1677 mm	1677 x 800 x 200 mm	84
CMS2 32"-65" Adjustable Ceiling Mount		32"-65"	60 kg	min. 100x100 max. 600x400	nd	min. 1775 mm max. 2575 mm	1775 x 800 x 200 mm	84
CMS3 32"-65" Fixed Ceiling Mount		32"-65"	120 kg	min. 75x75 max. 600x400	-12°/+6,5°	min. 1450 mm max. 2250 mm	1450 x 800 x 326 mm	85

► Flat Screen Desk Mount





Product	Image	Screen size	Max. capacity	VESA (mm)	Adjustment possibility	Extension	Dimensions (HxWxD)	Page
MSV1 32"-46" Screen Desk Mount		32"-46"	15 kg	min. 75x75 max. 200x200	40°	100-360 mm	405 x 220 x 120,5 mm	85
MSV2 32"-46" Screen Desk Mount		32"-46"	15 kg	min. 75x75 max. 200x200	40°	100-660 mm	705 x 220 x 120,5 mm	86

MENU BOARDS









Product	Image	Screen size	Adjustment range	Max. capacity	Extension range	Page
MB1155-L 42"-57" Menu board for 1 screen, Landscape		42"-57"	0°/+18°	70 kg	min.225 mm max.1125 mm	88
MBV2147-L 42"-47" Menu board for 2 screens, Landscape		42"-47"	0°/+18°	140 kg	min.225 mm max.1125 mm	88
MBV2155-L 50"-57" Menu board for 2 screens, Landscape		50"-57"	0°/+18°	140 kg	min.225 mm max.1125 mm	88
MBV3147-L 42"-47" Menu board for 3 screens, Landscape		42"-47"	0°/+18°	210 kg	min.225 mm max.1125 mm	88
MBV3155-L 50"-57" Menu board for 3 screens, Landscape		50"-57"	0°/+18°	210 kg	min.225 mm max.1125 mm	88
MBV1155-P 42"-57" Menu board for 1 screen, Portrait		42"-57"	0°/+18°	70 kg	min.225 mm max.1125 mm	89
MBV2147-P 42"-47" Menu board for 2 screens, Portrait		40"-47"	0°/+18°	140 kg	min.225 mm max.1125 mm	89
MBV2155-P 50"-57" Menu board for 2 screens, Portrait		50"-57"	0°/+18°	140 kg	min.225 mm max.1125 mm	89
MBV1155BB-L 42"-57" Menu board for back to back screens, Landscape		42"-57"	0°/+18°	70 kg	min.225 mm max.1125 mm	90
MBV2147BB-L 42"-47" Menu board for back to back screens, Landscape		42"-47"	0°/+18°	140 kg	min.225 mm max.1125 mm	90
MBV2155BB-L 50"-57" Menu board for back to back screens, Landscape		50"-57"	0°/+18°	140 kg	min.225 mm max.1125 mm	90
MBV3147BB-L 42"-47" Menu board for back to back screens, Landscape		42"-47"	0°/+18°	210 kg	min.225 mm max.1125 mm	90
MBV3155BB-L 50"-57" Menu board for back to back screens, Landscape		50"-57"	0°/+18°	210 kg	min.225 mm max.1125 mm	90
MBV1155BB-P 42"-57" Menu board for back to back screens, Portrait		42"-57"	0°/+18°	70 kg	min.225 mm max.1125 mm	91
MBV2147BB-P 42"-47" Menu board for 2 back to back screens, Portrait		42"-47"	0°/+18°	140 kg	min.225 mm max.1125 mm	91
MBV2155BB-P 50"-57" Menu board for 2 back to back screens, Portrait		50"-57"	0°/+18°	140 kg	min.225 mm max.1125 mm	91
MBV155W-L 42"-55" Menu Board for 1 screen, multiscreens configuration wall mount, Landscape		42"-55"	0°/+18°	60 kg	1500 mm	92
MBV455Q-L 42"-55" Ceiling Menu Board for 4 screens, Landscape		42"-55"	0°/+18°	70 kg	min.610 mm max. 1460 mm	92
MBV355T-L 42"-55" Ceiling Menu Board for 3 screens, triangle, Landscape		42"-55"	0°/+18°	70 kg	min.500 mm max.1350 mm	93
MBV455BBS-L 42"-55" Ceiling Menu board for 4 screens, back-to back, stacked mounts, Landscape		42"-55"	0°/+18°	100 kg	1270 mm	94

MONITOR MOUNTS







► Wall Monitor Mounts

Product	Image	Screen size	Adjustment range	Max. capacity	Extension range	Dimensions (HxWxD)	Page
GD22 19"-27" Monitor Fixed Wall Mount		19"-27"	nd	10 kg	18 mm	201,5x150x18 mm	96
GD01 19"-27" Monitor Swing Arm Wall Mount		19"-27"	180°	10 kg	min. 108 mm max. 472 mm	783x800x500 mm	96
GD02 19"-27" Monitor Swing Arm Wall Mount		19"-27"	180°	10 kg	min. 108 mm max. 307 mm	307x178x115 mm	97
GD03 19"-27" Monitor Wall Mount		19"-27"	nd	10 kg	25 mm	115x115x25 mm	97
GD04 19"-27" Monitor Fixed Wall Mount		19"-27"	180°	10 kg	106 mm	115x115x106 mm	98
GD20 19"-27" Monitor Swing Arm Wall Mount		19"-27"	140°	10 kg	124 mm	174x126x124 mm	99
GD24 19"-27" Monitor Multi Purpose Mount		19"-27"	145°	10 kg	91 mm	115x115x91 mm	99
GD18 19"-27" Monitor Swing Arm Wall Mount		19"-27"	180°	10 kg	min.108 mm max.792 mm	792x219x115 mm	100
GD26 19"-27" Monitor Swing Arm Wall Mount		19"-27"	100°	10 kg	100-600 mm	600x238x147 mm	101

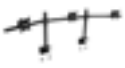





► Desk Monitor Mounts

Product	Image	Screen size	Adjustment range	Max. capacity	Dimensions (HxWxD)	Page
SV01 19"-27" Monitor Desk Mount		19"-27"	250°	10 kg	405x125x700 mm	101
SV03 19"-27" Desk Mount		19"-27"	160°	10 kg	405x125x700 mm	102
SV29 19"-27" Slim Pole Desk Mount		19"-27"	-90°/+30°	10 kg	875x125x45 mm	102
SV04 19"-27" Desk Mount with Swing Arm		19"-27"	250°	10 kg	405x125x528 mm	103
SV30 19"-27" Slim Pole Desk Mount		19"-27"	-90°/+30°	10 kg	405x125x366 mm	104
SV05 19"-27" Desk Mount for 2 Screens		19"-27"	160°	20 kg	405 x750x107 mm	106
SV06 19"-27" Swing Arm Desk Mount for 2 Screens		19"-27"	150°	20 kg	405x1050x107 mm	106
SV07 19"-27" Swing Arm Desk Mount for 4 Screens		19"-27"	160°	40 kg	705x7500x107 mm	107
SV08 19"-27" Dual Monitor Desk Mount		19"-27"	250°	20 kg	705x125x116 mm	108

► Desk Monitor Mounts



Product	Image	Screen size	Adjustment range	Max. capacity	Dimensions (HxWxD)	Page
SV10 19"-27" Triple Monitor Desk Mount		19"-27"	160°	30 kg	405x1400x108 mm	108
SV11 19"-27" Triple Monitor Desk Mount		19"-27"	160°	30 kg	405x1490x108 mm	109
SV16 19"-27" Desk Mount for 6 Screens		19"-27"	160°	60 kg	705x1400x108 mm	109
SV17 19"-27" Curved Desk Mount for 6 Screens		19"-27"	160°	60 kg	705x1490x108 mm	110
DM121 19"-27" Dual Monitor Desktop Arm Mount		19"-27"	0°/25°	20 kg	405x125x1300 mm	112
DM101 19"-27" Dual Monitor Desktop Arm Mount		19"-27"	0°/25°	10 kg	405x125x700 mm	113
DM141 19"-27" Dual Monitor Desktop Arm Mount		19"-27"	0°/25°	40 kg	705x125x1300 mm	114

► Medical Monitor Mounts / Undershaft Monitor Mounts / Ceiling Monitor Mounts





Product	Image	Screen size	Adjustment range	Max. capacity	Extension range	Dimensions (HxWxD)	Page
MSA01 19"-27" Adjustable Monitor Ceiling Mount		19"-27"	22,5°/-22,5°	10 kg	1744 mm	1744x2545x2490 mm	105
MSA02 19"-27" Swing Arm Wall Mount		19"-27"	22,5°/-22,5°	10 kg	1610 mm	1610x884x160 mm	104
USM1 19"-27" Under Shelf Monitor Mount		19"-27"	-12°/+90°	10 kg	299 mm	1610x884x160 mm	110
SV31 19"-27" Monitor Ceiling Mount		19"-27"	120°	10 kg	730 mm	730x119x135 mm	111
SV34 19"-27" Monitor Adjustable Ceiling Mount		19"-27"	120°	10 kg	1020-1720 mm	1720x119x145 mm	111
SV35 19"-27" Monitor Adjustable Ceiling Mount		19"-27"	120°	10 kg	1020-1720 mm	1720x119x145 mm	112

Cable Cubbies

Product	Image	no. ports	Weight	Dimensions (HxWxD)	Page
MCB103 Cable Cubby for 3 slots		3	0.7 kg	238x130x62 mm	116
MCB104 Cable Cubby for 4 slots		4	0.8 kg	285x130x62 mm	116
MCB202 Tilt Cable Cubby for 2 slots		2	0.8 kg	164x174.5x62 mm	117
MCB203 Tilt Cable Cubby for 3 slots		3	1 kg	216x174.5x62 mm	117



Product	Image	no. ports	Weight	Dimensions (HxWxD)	Page
MCB204 Tilt Cable Cubby for 4 slots		4	1.1 kg	277x174.5x62 mm	118
MCB205 Tilt Cable Cubby for 5 slots		5	1.3 kg	277x174.5x62 mm	119

POS MOUNTS

Product	Image	Screen Size	Weight	Dimensions (HxWxD)	Page
POS01 Double arm mount		19"-27"	15 kg	388x75x75 mm	122
POS02 Single arm mount		nd	5 kg	175x660x93 mm	122
POS03 Double arm mount		13"-19"	5 kg	388x75x75 mm	123
POS07 Double arm mount		19"-27"	15 kg	95x60x30 mm	124

TABLETS

► Tablet Enclosures









Product	Image	Max. capacity	Weight	Dimensions (HxWxD)	Page
IPM01 Tablet Mount		5 kg	0,8 kg	270x250x30 mm	126
ITE03 Tablet Enclosure		10 kg	4 kg	custom	126

► Stands

Product	Image	Max. capacity	Weight	Dimensions (HxWxD)	Page
ITSV03 ITSV Series Tablet Stands with VESA Adapter		8 kg	19 kg	400x450x1030 mm	127
ITSV03L ITSV Series Tablet Stands with VESA Adapter		8 kg	19 kg	400x450x1030 mm	127
ITSV03P ITSV Series Tablet Stands with VESA Adapter		8 kg	19 kg	400x450x1030 mm	127
ITS08 Indoor Tablet Stand		10 kg	12 kg	350x350x1050 mm	128
ITS07 Indoor Tablet Stand		10 kg	14 kg	250x300x1220 mm	129
ITSV01 ITSV Series Tablet Stands with VESA Adapter		5 kg	9 kg	400x400x1190 mm	129
ITSV02 ITSV Series Tablet Stands with VESA Adapter		5 kg	15 kg	350x350x1030 mm	130

INFOKIOSKS AND ENCLOSURES

► Indoor Systems

Product	Image	Screen Size	Weight	Dimensions (HxWxD)	Page
IDS02 Series 19"-27" Indoor Touch Kiosk		19"-27"	50 kg	1340x500x380 mm	132
IDS06 Series 32"-65" Public Display Kiosk		32"-65"	75 kg	1980x950x388,5 mm	132
IDS07 Series 42"-65" Public Display Stand		42"-65"	100 kg	2210x1235x295 mm	133
VX100 40"-65" Public Display Stand		40"-65"	110 kg	500x1100x2300 mm	134
VX200 40"-65" Public Display Stand		40"-65"	110 kg	500x930x2300 mm	135
VX300 40"-65" Public Display Stand		40"-65"	120 kg	600x1020x2325 mm	135
VX400 40"-47" Public Display Floor Stand		40"-47"	100 kg	600x1150x1400 mm	136
ODX100 40" - 65" Outdoor Kiosk Enclosure		40"-65"	100 kg	2100x1100x250 mm - 40"- 55" 2400x1250x250 mm - 55"- 65"	137

► Screen Enclosures

Product	Image	Screen Size	Weight	Dimensions (HxWxD)	Page
IEN01 Series 32"-65"LCD/LED Indoor Enclosure		46"	60 kg	1200x840x183 mm	136



PROJECTOR MOUNTS

FEATURES

3 step connection – easy assembly and connection in just 3 steps

Adjustment – flexible mounting pattern adjustment for all projector models

Height adjustable – variable height adjustment via telescopic pole

Cable management – integrated cable management for clean easy installation



Universal Projector Ceiling Mount (3 fixing points)

PM1

FEATURES

- Universal for all key projectors with multiple fixing points
- Telescopic mount including full height adjustment
- 360° full Horizontal adjustment
- Max weight capacity 15 kg

TECHNICAL



18°/18°



90°/90°



15 kg



min.448 mm
max.656mm



CEILING

PRODUCT SPECIFICATION

Dimensions (HxWxD)	Weight	Max capacity	Colour	Packaging dimensions
656x450x450 mm	3 kg	15 kg	black silver white	550x240x85 mm



Universal Projector Ceiling Mount (4 fixing points)

PM2

CEILING



FEATURES

- Universal for all key projectors with multiple fixing points
- Telescopic mount including full height adjustment
- 360° full Horizontal adjustment
- Max weight capacity 15 kg

TECHNICAL



18°/18°



90°/90°



15 kg



min.448 mm
max.656mm

PRODUCT SPECIFICATION

Dimensions (HxWxD)	Weight	Max capacity	Colour	Packaging dimensions
656x480x480 mm	3,3 kg	15 kg	black silver white	550x240x80 mm



CEILING



FEATURES

- Universal for all key projectors with multiple fixing points
- Telescopic mount including full height adjustment
- 360° full Horizontal adjustment
- Max weight capacity 15 kg

TECHNICAL

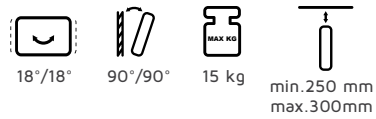

PRODUCT SPECIFICATION

Dimensions (HxWxD)	Weight	Max capacity	Colour	Packaging dimensions
300x420x420 mm	2,6 kg	15 kg	black silver white	185x185x290 mm



FEATURES

- Universal for all key projectors with multiple fixing points
- 360° full Horizontal adjustment
- Max weight capacity 15 kg

TECHNICAL

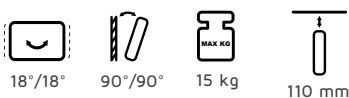

CEILING

PRODUCT SPECIFICATION

Dimensions (HxWxD)	Weight	Max capacity	Colour	Packaging dimensions
110x450x450 mm	1.3 kg	15 kg	black silver white	185x185x290 mm



FEATURES

- Universal for all key projectors with multiple fixing points
- Distance from ceiling to projector 650 mm to 1100 mm
- Internal cable management in pole
- Professional micro adjustment ensures precise installation
- 360° full horizontal adjustment
- New Micro-Adjustment Mechanism

PRODUCT SPECIFICATION

	Weight	Max capacity	Extension	Colour	Packaging dimensions
PM8	4,5 kg	20 kg	740-1100 mm	black silver white	670x240x80 mm
PM8.1	4,0 kg	20 kg	540-740 mm	black silver white	670x240x80 mm
PM8.2	6 kg	20 kg	1100-1900 mm	black silver white	670x240x80 mm
PM8.3	3 kg	20 kg	270 mm	670x240x80 mm	

TECHNICAL



0°/90°



+7,5°/-7,5°



20 kg



270-1900 mm



WALL



FEATURES

- Universal for all key projectors with multiple fixing points
- Distance from wall to projector 650 mm to 1100 mm
- Internal cable management in pole
- Professional micro adjustment ensures precise installation
- 360° full horizontal adjustment

TECHNICAL

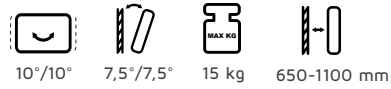

PRODUCT SPECIFICATION

Product	Dimensions (HxWxD) mm	Weight	Max capacity	Colour	Packaging dimensions
WPM1	870x280x180	6 kg	15 kg	black silver white	900x300x200 mm
WPM1.1	590x280x180	5 kg	15 kg	black silver white	900x300x200 mm



FEATURES

- Universal for all key projectors
- Adjustable tilt angle from 5° to 15°
- Height adjustment from 810 mm to 1217 mm
- Professional industrial casters with brake mechanism

TECHNICAL

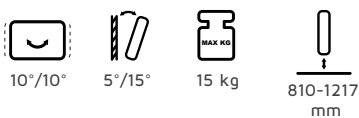

CEILING

PRODUCT SPECIFICATION

Dimensions (HxWxD) mm	Weight	Max capacity	Colour	Packaging dimensions
510x460x810	15 kg	15 kg	black silver	600x560x900 mm



FEATURES

- Modern Design with a high-end finish
- Aluminum construction with a semi-textured powder coat or anodized finish
- Ceiling plate covers to hide fixings included
- Micro-Adjustment mechanism ensures precise installation
- Universal for all key projectors with multiple fixing points
- Distance from ceiling to projector from 450 mm to 1700 mm
- Internal cable management in tube
- 45° horizontal adjustment



PRODUCT SPECIFICATION

	Dimensions (HxWxD)	Weight	Max capacity	Extension	Colour	Packaging dimensions
PMV100	450x180x180 mm	4,5 kg	15 kg	450-650 mm	black silver white	500x200x200 mm
PMV200	650x180x180 mm	5 kg	15 kg	650-1000 mm	black silver white	700x200x200 mm
PMV300	1000x180x180 mm	6 kg	15 kg	1000-1700 mm	black silver white	1050x200x200 mm

TECHNICAL



**NEW
PRODUCT**



FEATURES

- Modern Design with a high-end finish
- Aluminum construction with a semi-textured powder coat or anodized finish
- Micro-Adjustment mechanism ensures precise installation
- Wall plate covers to hide fixings included
- Universal for all key projectors with multiple fixing points
- Distance from wall to projector from 500 mm to 1300 mm
- Internal cable management in tube
- 45° horizontal adjustment

PRODUCT SPECIFICATION

	Dimensions (HxWxD)	Weight	Max capacity	Extension	Colour	Packaging dimensions
WPMV100	590x250x180 mm	4,5 kg	15 kg	500-800 mm	black silver white	750x200x200 mm
WPMV200	890x250x180 mm	5,8 kg	15 kg	800-1300 mm	black silver white	1050x200x200 mm

TECHNICAL





PMARM100 Decorative finishing ring for projectors

Colour	Packaging dimensions
black silver white	150x50x30 mm





TROLLEYS AND STANDS

FEATURES

Universal – VESA mount and adapters included ensuring total screen compatibility

Adjustable – full Height and Tilt adjustment for mobility and varying requirements

Reliability – Professional casters with brake mechanism for security and safety

Flexibility – range of options from 1 to 4 screens for total mounting solution



32"-47" Display Stand

STD16

FEATURES

- Universal VESA interface suitable for all screen types
- Fully height adjustable
- Adjustable tilt angle from -6° to 9°
- Heavy stable base
- Full internal cable management

TECHNICAL



min.
75x95 mm
max.
600x400 mm



32"-47"



-6,5°/+12°



30 kg



300-1600 mm



STANDS

PRODUCT SPECIFICATION

Dimensions (HxWxD)	Weight	Max capacity	Colour	Packaging dimensions
1720x800x570 mm	25 kg	30 kg	black silver	1800x360x140 mm



37"-60" Stand and Trolley for 2 displays

STD17D

STANDS



FEATURES

- Multifunctional base plate which can be used as free standing or trolley – casters included
- Fully height adjustable
- Full internal cable management
- Universal VESA interface suitable for all screen types

TECHNICAL



min.
75x95 mm
max.
600x400 mm



37"-60"



-6°/+9°



50 kg



300-1600 mm

PRODUCT SPECIFICATION

Dimensions (HxWxD)	Weight	Max capacity	Colour	Packaging dimensions
1750x1200x740 mm	55 kg	50 kg	black silver	1800x730x140 mm

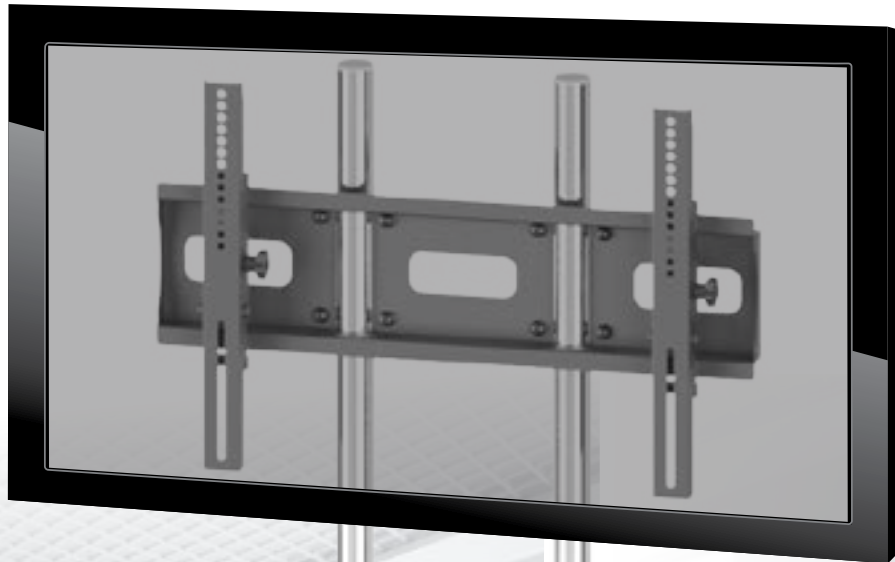

FEATURES

- Multifunctional base plate which can be used as free standing or trolley – casters included
- Fully height adjustable
- Full internal cable management
- Universal VESA interface suitable for all screen types



PRODUCT SPECIFICATION

Dimensions (HxWxD)	Weight	Max capacity	Colour	Packaging dimensions
1750x1200x740 mm	47 kg	50 kg	black silver white	1800x730x140 mm

TECHNICAL

min. 75x95 mm
 max. 600x400 mm
 37"-60"
 -6°/+9°
 50 kg
 300-1600 mm



42"-50" Display Stand with Enclosure

STD25

FEATURES

- Modern design with high-end finish
- Heavy stable base with additional space for media player
- Customization options
- Universal VESA interface suitable for all screens
- Full internal cable management
- Tubular chrome pole luxury finish

TECHNICAL

min.
400x400 mm
max.
600x400 mm

42"-50"

2000 - 2330
mm



STANDS

PRODUCT SPECIFICATION

Dimensions (HxWxD)	Weight	Max capacity	Colour	Packaging dimensions
2285x700x370 mm	71 kg	71 kg	black white	2300x700x400 mm



42"-70" Flat Screen Trolley

TR1

TROLLEYS



FEATURES

- Universal VESA interface suitable for all screen types
- Adjustable tilt angle from -6° to 9°
- Fully height adjustable
- Full internal cable management
- Professional industrial casters with brake mechanism
- Tubular chrome pole luxury finish

TECHNICAL

min.
75x75 mm
max.
600x400 mm

42"-70"



min.
300 mm
max.
1700 mm



min.
50x95 mm
max.
750x460 mm

MAX KG
80 kg

PRODUCT SPECIFICATION

Dimensions (HxWxD)	Weight	Max capacity	Colour	Packaging dimensions
1125x700x1780 mm	30 kg	80 kg	black silver	1800x730x140 mm

-6°/+9°

-3,3° / +3,3°



FEATURES

- Universal VESA interface suitable for all screen types
- Fully height adjustable
- Heavy stable base with optional mounting direct to floor
- Full internal cable management

PRODUCT SPECIFICATION

Dimensions (HxWxD)	Weight	Max capacity	Colour	Packaging dimensions
1700x800x350 mm	25 kg	80 kg	black silver	1800x360x140 mm

TECHNICAL



min. 75x75 mm
max. 600x400 mm



32"-55"



min. 310 mm
max. 1700 mm



min. 50x95 mm
max. 750x460 mm



80 kg



FEATURES

- Universal VESA interface suitable for all screen types
- Adjustable tilt angle from 0° to 45°
- Heavy stable base with optional mounting direct to floor
- Full internal cable management
- Tubular chrome pole luxury finish

PRODUCT SPECIFICATION

Dimensions (HxWxD)	Weight	Max capacity	Colour	Packaging dimensions
1048,5x559x350 mm	22 kg	15 kg	black silver	1150x360x140 mm

TECHNICAL



min.
75x75
max.
100x100
mm



19"-32"



0°/45°



min.
75x75 mm
max.
100x100 mm



15 kg

TRV100

42"-55" Video Conferencing Trolley



TROLLEYS



FEATURES

- Modern Design with a high-end finish
- Aluminum construction with a semi-textured powder coat or anodized finish
- Fully height adjustable
- Fully integrated cable management
- Universal VESA interface suitable for all screen types

TECHNICAL



min.
100x100 mm
max.
600x400 mm



42"-55"



70 kg



min.
300 mm
max.
1700 mm



0°/11°

PRODUCT SPECIFICATION

Dimensions (HxWxD)	Weight	Max capacity	Colour	Packaging dimensions
1850x1050x900 mm	40 kg	70 kg	black silver white	1950x1150x1000 mm

TRV200

60"-75" Video Conferencing Trolley



FEATURES

- Modern Design with a high-end finish
- Aluminum construction with a semi-textured powder coat or anodized finish
- Fully height adjustable
- Fully integrated cable management
- Universal VESA interface suitable for all screen types

TECHNICAL



min.
100x100 mm
max.
800x400 mm



60"-75"



120 kg



min.
300 mm
max.
1700 mm



0°/11°



TROLLEYS

PRODUCT SPECIFICATION

Dimensions (HxWxD)	Weight	Max capacity	Colour	Packaging dimensions
1850x1250x900 mm	45 kg	120 kg	black silver white	1950x1350x1000 mm



FEATURES

- Modern Design with a high-end finish
- Aluminum construction with a semi-textured powder coat or anodized finish
- Fully height adjustable
- Fully integrated cable management
- Universal VESA interface suitable for all screen types

PRODUCT SPECIFICATION

Dimensions (HxWxD)	Weight	Max capacity	Colour	Packaging dimensions
1850x1960x900 mm	50 kg	120 kg	black silver white	1950x2060x1000 mm

TECHNICAL

 42"-55"
  120 kg
  0°/11°

min. 100x100 mm
 max. 600x400 mm

min. 300 mm
 max. 1700 mm



TROLLEYS



FEATURES

- Universal VESA interface suitable for all screen types
- Flexible option of mounting 2 screens
- Adjustable tilt angle from -6° to 9°
- Fully height adjustable
- Full internal cable management
- Professional industrial casters with brake mechanism

TECHNICAL

min. 75x75 mm
max. 600x400 mm

37"-60"

min. 200 mm
max. 2000 mm

min. 50x95 mm
max. 750x460 mm

80 kg

-6°/+9° -3,3° / +3,3°

PRODUCT SPECIFICATION

Dimensions (HxWxD)	Weight	Max capacity	Colour	Packaging dimensions
2083x1116x802 mm	50 kg	80 kg	black silver	1200x600x140 mm



FEATURES

- Universal VESA interface suitable for all screen types
- Adjustable tilt angle from -6° to 9°
- Fully height adjustable
- Full internal cable management
- Professional industrial casters with brake mechanism
- Tubular chrome pole luxury finish

TECHNICAL

min. 75x75 mm
max. 400x400 mm

37"-60"

min. 520 mm
max. 1700 mm

min. 50x95 mm
max. 750x460 mm

80 kg

TROLLEYS



PRODUCT SPECIFICATION

Dimensions (HxWxD)	Weight	Max capacity	Colour	Packaging dimensions
1700x1140x703 mm	24,4 kg	80 kg	black silver	1800x730x140 mm



FEATURES

- Universal VESA interface suitable for all screen types
- Adjustable tilt angle from -6° to 9°
- Fully height adjustable
- Full internal cable management
- Professional industrial casters with brake mechanism
- Tubular chrome pole luxury finish

PRODUCT SPECIFICATION

Dimensions (HxWxD)	Weight	Max capacity	Colour	Packaging dimensions
1150x700x1770 mm	30 kg	80 kg	black silver	1800x730x140 mm

TECHNICAL

min.
75x75 mm
max.
600x400 mm

32"-60"

-3,3°/+3,3°

min.
250 mm
max.
1700 mm

min.
50x95 mm
max.
750x460 mm

MAX KG
80 kg

-6°/+9°

TR7

37"-60" Flat Screen AV Trolley



TROLLEYS



FEATURES

- Universal VESA interface suitable for all screen types
- Full internal cable management
- Professional industrial casters with brake mechanism
- Additional mounting shelf included
- Tubular chrome pole luxury finish
- Max weight capacity 80 kg

TECHNICAL

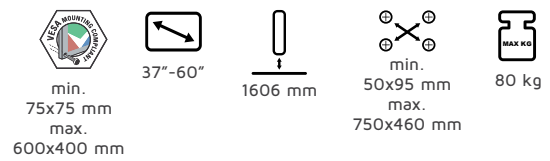

PRODUCT SPECIFICATION

Dimensions (HxWxD)	Weight	Max capacity	Colour	Packaging dimensions
1606x897x536 mm	65 kg	80 kg	black silver	1150x360x140 mm

TR8

37"-60" Low Level Flat Screen Trolley



FEATURES

- Universal VESA interface suitable for all screen types
- Adjustable tilt angle from 0° to 28°
- Full internal cable management
- Tubular chrome pole luxury finish
- Professional industrial casters with brake mechanism
- Max weight capacity 80 kg

TECHNICAL

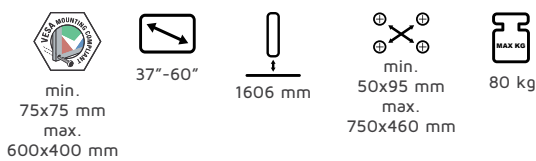

TROLLEYS

PRODUCT SPECIFICATION

Dimensions (HxWxD)	Weight	Max capacity	Colour	Packaging dimensions
1006x1070x500 mm	45 kg	80 kg	black silver	1800x730x180 mm



19"-27" Universal Adjustable Trolley with PC Mount

SV53

FEATURES

- Universal VESA interface suitable for all screen types
- Additional mounting shelf included
- Fully height adjustable
- Adjustable tilt angle 250°
- 360° rotation for portrait or horizontal screen option
- Easy position adjustment

TECHNICAL

min. 75x75 mm max. 100x100 mm

19"-27"

1270 mm

min. 75x75 mm max. 100x100 mm

10 kg

250°

360°



TROLLEYS

PRODUCT SPECIFICATION

Dimensions (HxWxD)	Weight	Max capacity	Colour	Packaging dimensions
1270x690x690 mm	18 kg	10 kg	black silver	1060x620x220 mm



40"-47" Dual Flat Screen AV Trolley

TR14



TROLLEYS

FEATURES

- Universal VESA interface suitable for all screen types
- Flexible option of mounting 2 screens
- Fully height adjustable
- Full internal cable management
- Professional industrial casters with brake mechanism

TECHNICAL

min. 100x100 mm max. 600x400 mm

40"-47"

min. 300 mm max. 1600 mm

min. 50x95 mm max. 750x460 mm

80 kg

PRODUCT SPECIFICATION

Dimensions (HxWxD)	Weight	Max capacity	Colour	Packaging dimensions
1850x1800x815 mm	61,3 kg	80 kg	black silver	1800x730x140 mm

TR18

60"-95" Flat Screen AV Trolley



TROLLEYS



FEATURES

- Universal VESA interface suitable for all screen types
- Full internal cable management
- Fully height adjustable
- Professional industrial casters with brake mechanism
- Tubular chrome pole luxury finish
- Max weight capacity 80 kg

TECHNICAL

min. 75x75 mm
max. 800x400 mm

60"-95"

300-1700 mm

min. 50x95 mm
max. 850x460 mm

80 kg

PRODUCT SPECIFICATION

Dimensions (HxWxD)	Weight	Max capacity	Colour	Packaging dimensions
1869x1705x815 mm	55,6 kg	80 kg	black silver	1800x730x140 mm

TR20

50"-60" Dual Flat Screen AV Trolley



FEATURES

- Universal VESA interface suitable for all screen types
- Flexible option of mounting 2 screens
- Fully height adjustable
- Full internal cable management
- Professional industrial casters with brake mechanism
- Max weight capacity 80 kg

TECHNICAL

min. 75x75 mm
max. 600x400 mm

50"-60"

min. 300 mm
max. 1700 mm

min. 50x75 mm
max. 850x460 mm

80 kg

TROLLEYS



PRODUCT SPECIFICATION

Dimensions (HxWxD)	Weight	Max capacity	Colour	Packaging dimensions
1847x2200x815 mm	67,5 kg	80 kg	black silver	1800x730x140 mm



ETR Series Electric height-adjustable AV Trolleys

FEATURES

- Fully electrical height adjustable
- Universal VESA interface suitable for all screen types
- Adjustable tilt angle from 0° to 90°
- Professional industrial casters with brake mechanism

FEATURES PHOTO



TROLLEYS

PRODUCT SPECIFICATION

Product	Screen size	Max. capacity	VESA	Weight	Dimensions (HxWxD)
ETR3	40-55"	60 kg	min. 100x100 max. 600x400	45 kg	1200x900x750 mm
ETR4	60-95"	60 kg	min. 200x100 max. 600x400	45 kg	1450x900x750 mm



ETRE Series Full Electric height-adjustable AV Trolleys



TROLLEYS

FEATURES

- Universal VESA interface suitable for all screen types
- Adjustable tilt angle from 0° to 90°
- Fully height adjustable
- Full internal cable management
- Professional industrial casters with brake mechanism
- Tubular chrome pole luxury finish

FEATURES PHOTO



PRODUCT SPECIFICATION

Product	Screen size	Max. capacity	VESA	Weight	Dimensions (HxWxD)
ETRE3	40-55"	60 kg	min. 100x100 max. 400x200	60 kg	1200x900x750 mm
ETRE4	60-95"	60 kg	min. 100x100 max. 800x400	80 kg	1382x1500x723 mm

VCTX Series Video Conferencing Trolley with height adjustment



TROLLEYS



FEATURES

- Fully height adjustable
- Universal VESA interface suitable for all screen types
- Includes storage space for PC and VC equipment
- Professional casters with brake mechanism
- Additional camera shelf included

FEATURES PHOTO



PRODUCT SPECIFICATION

Product	Screen size	Max. capacity	VESA	Weight	Dimensions (HxWxD)
VCTX170	42-70"	80 kg	min. 100x100 max. 800x400	97 kg	1100x1958x873 mm
VCTX190	79-90"	80 kg	min. 100x100 max. 800x400	100 kg	1100x1958x873 mm

50"-60" VCTR260 Video Conferencing Trolley for 2 Screens



FEATURES

- Universal VESA interface suitable for all screen types
- Flexible option of mounting 2 screens
- Includes storage space for PC and VC equipment
- Fully height adjustable
- Full Internal Cable management

FEATURES PHOTO



TROLLEYS

Product	Screen size	Max. capacity	VESA	Weight	Dimensions (HxWxD)
VCTR260	50-60"	80 kg	min. 75x75 max. 600x400	93 kg	1874x2200x815 mm



FEATURES

- Fully height adjustable
- Universal VESA interface suitable for all screen types
- Adjustable tilt angle from 0° to 90°
- Professional industrial casters with brake mechanism

TECHNICAL



min.
100x100
max.
600x400
mm



50"-55"



80 kg

PRODUCT SPECIFICATION

Product	Screen size	Max capacity	VESA	Weight	Colour
VCTX247	40-47"	80 kg	min. 100x100 mm max. 600x400 mm	97 kg	silver
VCTX255	50-55"	80 kg	min. 200x100 mm max. 600x400 mm	100 kg	silver



VIDEOCONFERENCING



PRODUCT SPECIFICATION

Dimensions	Weight	Max capacity	Colour	Packaging dimensions
1845x1705x878 mm	84,6 kg	80 kg	black silver	1800x730x800 mm

FEATURES

- Universal VESA interface suitable for all screen types
- Supporting heavy displays up to 80 kg
- Fully height adjustable
- Includes storage space for PC and VC equipment
- Full internal cable management

TECHNICAL



min.
100x100 mm
max.
1000x600 mm



65"-95"



min.
1030mm
max.
1850 mm



min.
50x95mm
max.
750x460 mm



80 kg



ACCESSORIES

Video Conferencing Camera Shelf for TR1/TR2/TR3 Trolley

CH1



Colour	Packaging dimensions
inox	550x250x150 mm

Video Conferencing Camera Holder for LWB, PWB, TWB

CH3



Colour	Packaging dimensions
inox	480x260x150 mm

Video Conferencing Camera Holder for 40"-55" displays

CH4



Colour	Packaging dimensions
black silver	550x250x150 mm

Video Conferencing Camera Holder for >55" displays

CH5



Colour	Packaging dimensions
silver	550x250x150 mm

Rotating adapter for TR1/TR3

RH1



Colour	Packaging dimensions
black grey	650x520x120 mm

Glass shelf for TR1/TR3 trolleys

TRS1



Colour	Packaging dimensions
black grey	650x520x120 mm

Glass shelf with handle for TR1/TR3 trolleys

TRS2



Colour	Packaging dimensions
black grey	650x520x120 mm



TRS4

Glass shelf with handle TR5/TR6 trolleys

Colour	Packaging dimensions
black grey	650x250x120 mm



TRSM100

Metal shelf for TR5/TR6 trolleys

Colour	Packaging dimensions
black silver white	650x520x120 mm



TRSM1

Metal shelf for TR14/TR18/TR20

Colour	Packaging dimensions
black	750x320x50 mm



TRSM300

AV shelf for LWB/PWB/TWB Series

Colour	Packaging dimensions
black	350x280x520 mm



TRSM400

Soundbar bracket for LWB/PWB/TWB Series

Colour	Packaging dimensions
black	395x195x3 mm



RF1 (4 pcs)

Rubber feet (4x)

Colour	Packaging dimensions
black	135x135x55 mm





VIDEO WALLS

FEATURES

Professional adjustment – 8 point tool-less adjustment for precision installation

Universal - design for all screens 42"-95" with dedicated spacer kit solution

Pop Out – simple effective push/pop out design for fast extension and retraction

Serviceable – Full service access including prop out stand for safety and convenience



VWPOP Landscape Series - Quick Release Pop-Out Universal Video Wall Mount

VWPOP65-L

The VWPOP65-L is purpose designed for easy and fast servicing of recessed multi-screen installations. The simple one touch „pop out“ mechanism allows full extension of the display out of the videowall so access and servicing can be performed quickly and safely. Tool-less micro-adjustment is included for seamless alignment of the displays and precision dedicated spacers eliminate requirement for on-site calculations and measurements.

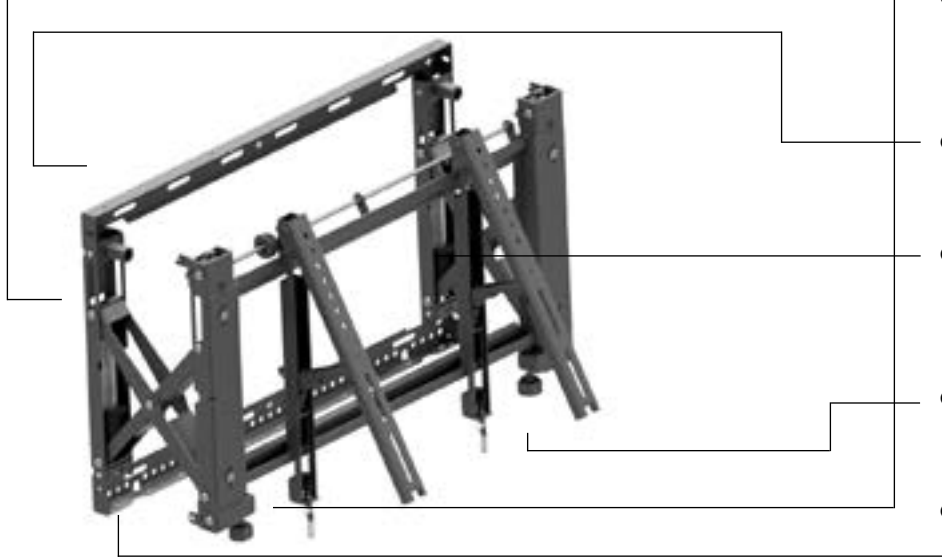

FEATURES

- Tool-less independent 8-point micro-adjustment provides seamless alignment of the displays max. 15 mm.
- Fast Release Pop-out mechanism provides convenient display access designed for used in enclosed or recessed installations.
- Pop-out mechanism can be temporarily removed with security locking screw to prevent unintentional pop-outs.
- Open Frame design allows full electrical wiring access and Integrated cable management strips make display-to-display cabling simple.
- Sequentially drilled wall plate and precision dedicated display spacers eliminate requirement for on-site calculations.
- Fast Release Pop-Out mechanism can be adjusted for varying display weights, ensuring safe and controlled extension.

tool-less micro-adjustment

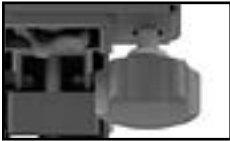

security padlock



dedicated spacers



FEATURES



min.
100x100
max.
600x400
mm



42"-85"



85-270 mm



0-28°



60 kg

ACCESSORIES

SPACERS



TECHNICAL

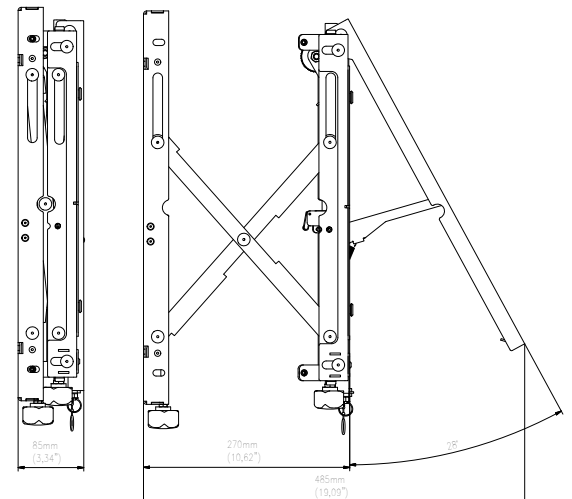
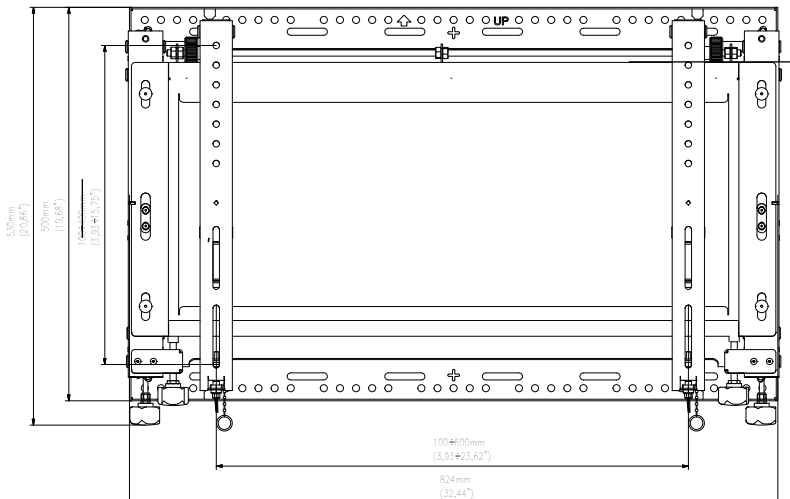



Product	Screen size	max. capacity	max. VESA	Weight	Dimensions (HxWxD)
VWPOP65-L	42"-85"	60 kg	600x400 mm	14 kg	824x530x80 mm
VWPOP95-L	70"-95"	130 kg	800x600 mm	30 kg	1084x700x100 mm



VWFS Landscape Series - Full Service Universal Video Wall

The VWFS Series is purpose designed for easy and fast servicing in video wall installations. The full service mechanism allows extension of the display out of the videowall so access and servicing can be performed quickly and safely. Tool-less micro-adjustment is included for seamless alignment of the displays and precision dedicated spacers eliminate requirement for on-site calculations and measurements.

FEATURES



- Mechanism extension includes upward tilt position with prop stands holding weight of display for easy and safe servicing.
- Open Frame design allows full electrical wiring access and integrated cable management strips make display-to-display cabling simple
- Sequentially drilled wall plate and precision dedicated display spacers eliminate requirement for on-site calculations.
- Tool-less independent 8-point micro-adjustment provides seamless alignment of the displays.
- Pull-out/prop-open mechanism provides quick and easy access for servicing.

tool-less micro-adjustment

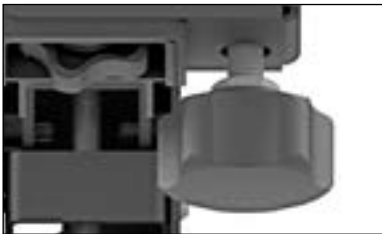

security padlock



full service access



ACCESSORIES

SPACERS



Product	Screen size	Max. capacity	Max. VESA	Weight	Dimensions (HxWxD)
VWFS65-L	42"-85"	60 kg	600x400 mm	13,5 kg	824x500x80 mm
VWFS95-L	90"-95"	130 kg	800x600 mm	26 kg	1070x670x100 mm



The VWFX is purpose designed for easy and fast installation in video wall installations and for forward tilting walls and menu board applications up to 45°. The VWFX65-L is designed for modular use with models VWPOP and VWFS or alternatively where full service access is not required. Tool-less micro-adjustment is included for seamless alignment of the displays and precision dedicated spacers eliminate requirement for on-site calculations and measurements.

FEATURES



- Designed for use in forward tilting walls and menu board applications up to 45°.
- Sequentially drilled wall plate and precision dedicated display spacers eliminate requirement for on-site calculations.
- Tool-less independent 8-point micro-adjustment provides seamless alignment of the displays.
- Adjustable VESA mounting patterns from 100 x 100 up to 600 x 400.
- Modular mount for unlimited video wall display configurations, can be used with models VWPOP and VWFS.

tool-less micro-adjustment

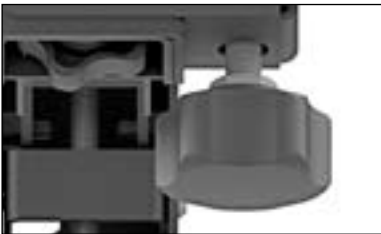

security padlock



dedicated spacers



ACCESSORIES

SPACERS



Product	Screen size	Max. capacity	Max. VESA	Weight	Dimensions (HxWxD)
VWFX65-L	42"-85"	60 kg	600x400 mm	11 kg	826x500x80 mm
VWFX95-L	90"-95"	130 kg	800x600 mm	32 kg	1076x670x100 mm



The VWPOP is purpose designed for easy and fast servicing of recessed video wall installations. The simple one touch „pop out” mechanism allows full extension of the display out of the videowall so access and servicing can be performed quickly and safely. Tool-less micro-adjustment is included for seamless alignment of the displays and precision dedicated spacers eliminate requirement for on-site calculations and measurements.

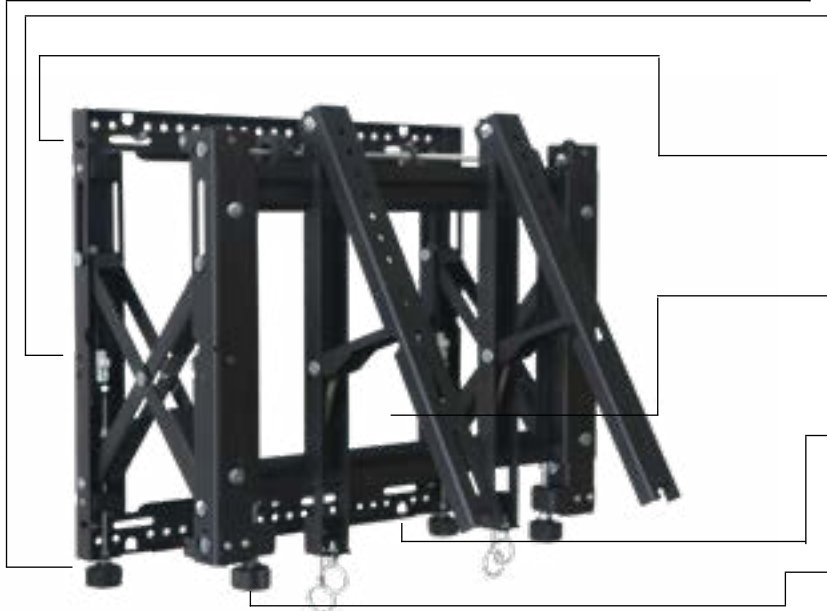

FEATURES

- Fast Release Pop-Out mechanism can be adjusted for varying display weights, ensuring safe and controlled extension.
- Fast Release Pop-out mechanism provides convenient display access designed for used in enclosed or recessed installations.
- Pop-out mechanism can be temporarily removed with security locking screw to prevent unintentional pop-outs.
- Open Frame design allows full electrical wiring access and Integrated cable management strips make display-to-display cabling simple.
- Sequentially drilled wall plate and precision dedicated display spacers eliminate requirement for on-site calculations.
- Tool-less independent 8-point micro-adjustment provides seamless alignment of the displays.

tool-less micro-adjustment



full service access



dedicated spacers



FEATURES



40"-85"



60 kg

ACCESSORIES

SPACERS





Product	Screen size	max. capacity	max. VESA	Weight	Dimensions (HxWxD)
VWPOP65-P	42"-85"	60 kg	400x600 mm	12,5 kg	512x530x80 mm
VWPOP95-P	90"-95"	130 kg	600x600 mm	30 kg	876x670x100 mm



VWFS Portrait Series - Full Service Universal Video Wall

The VWFS Series is purpose designed for easy and fast servicing in video wall installations. The full service mechanism allows extension of the display out of the videowall so access and servicing can be performed quickly and safely. Tool-less micro-adjustment is included for seamless alignment of the displays and precision dedicated spacers eliminate requirement for on-site calculations and measurements.

FEATURES

- Mechanism extension includes upward tilt position with prop stands holding weight of display for easy and safe servicing.
- Open Frame design allows full electrical wiring access and Integrated cable management strips make display-to-display cabling simple.
- Sequentially drilled wall plate and precision dedicated display spacers eliminate requirement for on-site calculations.
- Tool-less independent 8-point micro-adjustment provides seamless alignment of the displays.
- Pull-out/prop-open mechanism provides quick and easy access for servicing.

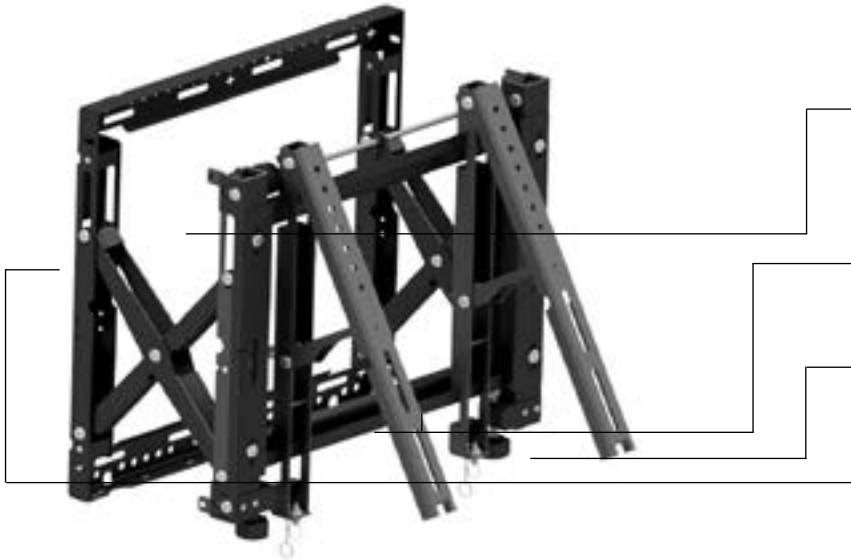

tool-less micro-adjustment

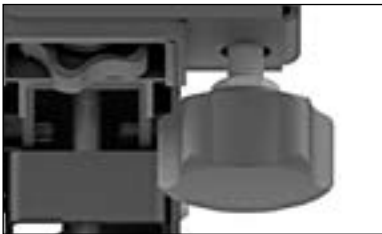

security padlock



dedicated spacers



FEATURES



42"-85"



60 kg

ACCESSORIES

SPACERS



Product	Screen size	Max. capacity	Max. VESA	Weight	Dimensions (HxWxD)
VWFS65-P	42"-85"	60 kg	400-600 mm	12 kg	512x500x80 mm
VWFS95-P	90"-95"	130 kg	600-600 mm	24 kg	876x670x100 mm



The VWFX Series is purpose designed for easy and fast installation in video wall installations and for forward tilting walls and manu board applications up to 45°. The VWFX65-L is designed for modular use with models VWPOP and VWFS or alternatively where full service access is not required. Tool-less micro-adjustment is included for seamless alignment of the displays and precision dedicated spacers eliminate requirement for on-site calculations and measurements.

FEATURES

- Designed for use in forward tilting walls and menu board applications up to 45°.
- Sequentially drilled wall plate and precision dedicated display spacers eliminate requirement for on-site calculations.
- Tool-less independent 8-point micro-adjustment provides seamless alignment of the displays.
- Adjustable VESA mounting patterns from 100x100 up to 600x400
- Modular mount for unlimited video wall display configurations, can be used with models VWPOP and VWFS.

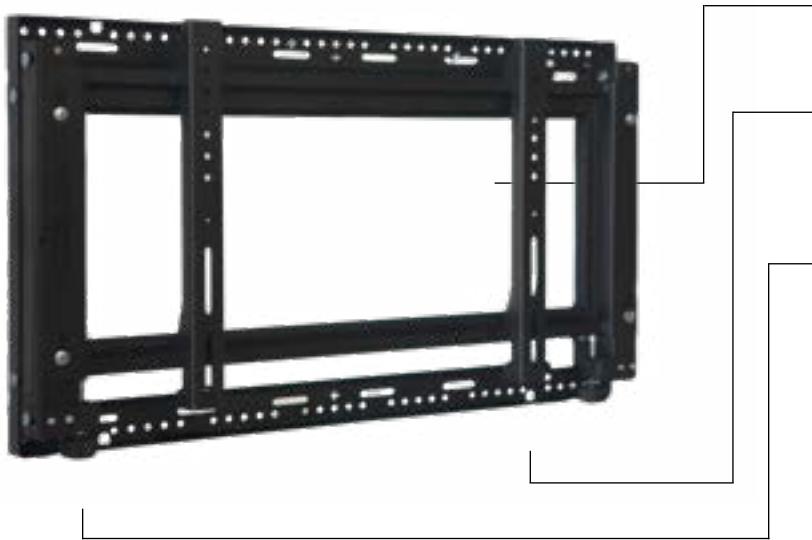

tool-less micro-adjustment

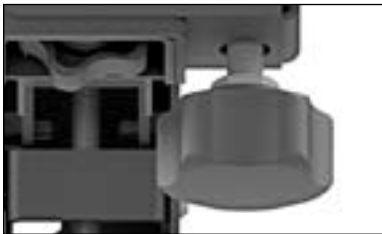

security padlock



dedicated spacers



FEATURES



42"-85"



60 kg

ACCESSORIES

SPACERS



Product	Screen size	Max. capacity	Max. VESA	Weight	Dimensions (HxWxD)
VWFX65-P	42"-85"	60 kg	400-300 mm	9,5 kg	500x514x80 mm
VWFX95-P	90"-95"	130 kg	600-600 mm	30 kg	670x876x100 mm

The VWW2255POP-L is purpose designed for easy and fast servicing of recessed video wall installations. The simple one touch „pop out“ mechanism allows full extension of the display out of the videowall so access and servicing can be performed quickly and safely.

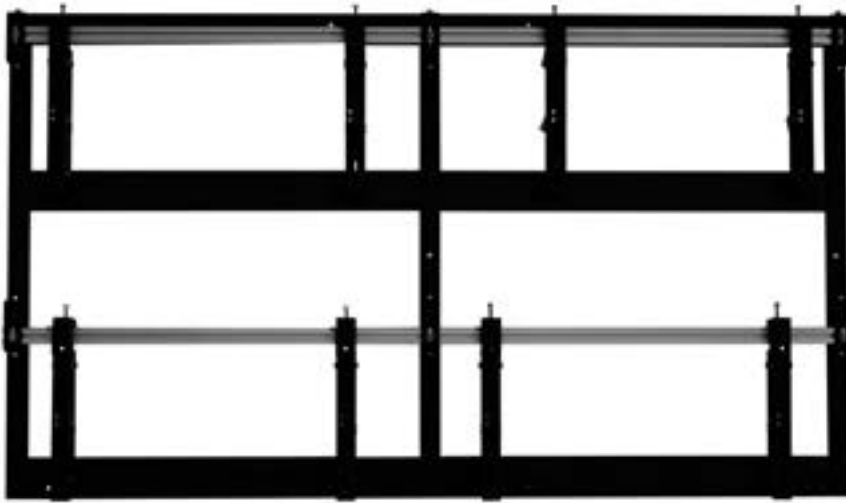

FEATURES

- Tool-less independent 8-point micro-adjustment provides seamless alignment of the displays.
- Pull-out/prop-open mechanism provides quick and easy access for servicing.
- Open Frame design allows full electrical wiring access and integrated cable management strips make display-to-display cabling simple.
- Adjustable VESA mounting patterns from 100x100 up to 600x400.

FEATURES



50"-55"



min.
100x100 mm
max.
600x400 mm



200 kg



min.
100x100
max.
400x600
mm

PRODUCT SPECIFICATION

PACKAGE SPECIFICATION

Dimensions (HxWxD)	Weight	Max capacity	Colors
2100x1210x100 mm	52 kg	200 kg	black

Dimensions	Weight	Package
2150x1300x150 mm	14 kg	brown box

TECHNICAL

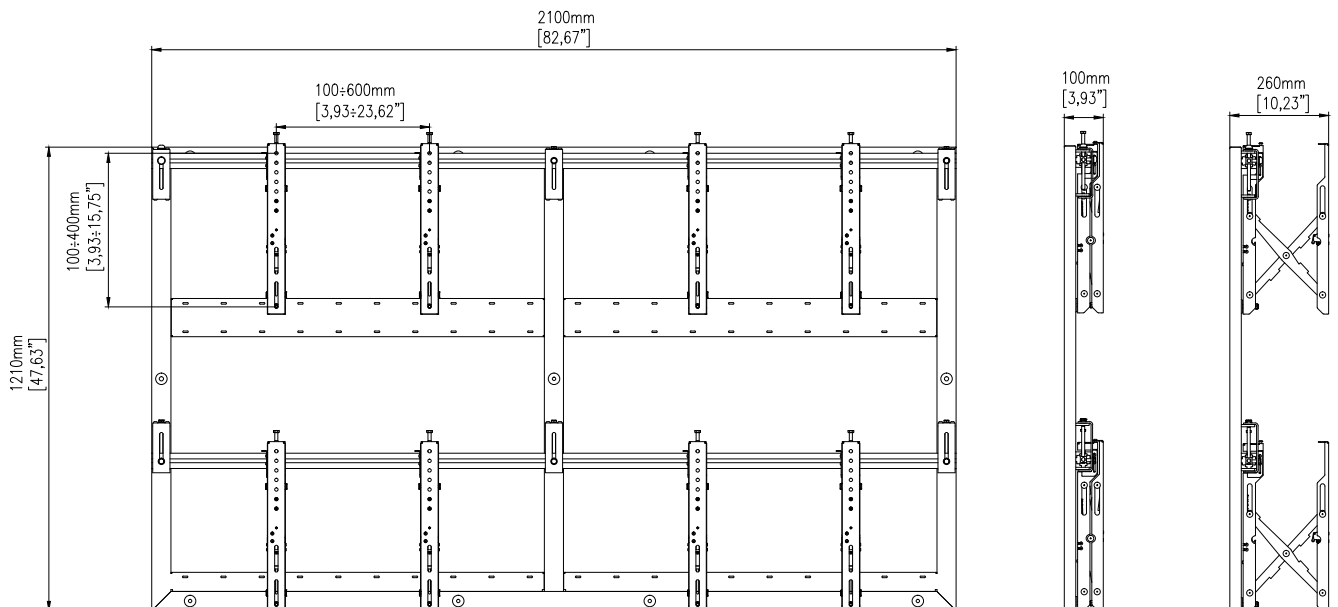



FEATURES

- Modular mount - the possibility of screens configuration
- Tool-less independent 8-point microadjustment provides seamless alignment of the displays
- Open Frame design allows full electrical wiring access and integrated cable management strips make display-to-display cabling simple
- Adjustable VESA mounting patterns from 100x100 up to 600x400

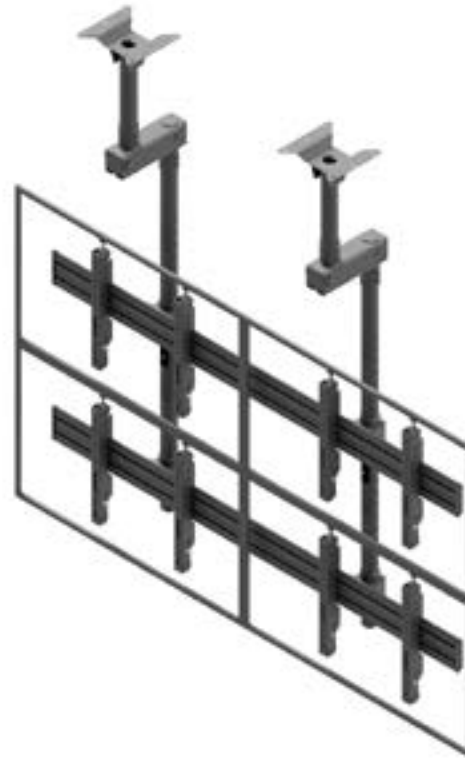

FEATURES PHOTO

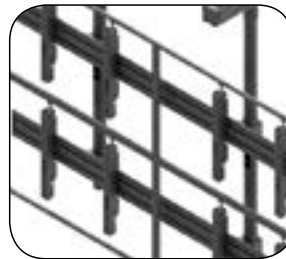
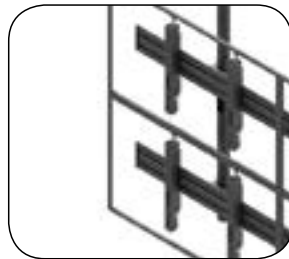

Monitor Configuration	Product	Screen size	Max. capacity	Max. VESA	Weight	Dimensions (HxWxD)
	VWCA2247-L	42"-47"	130 kg	min. 100x100 mm max. 600x400 mm	70 kg	2200x1960x370 mm
	VWCA2257-L	50"-57"	125 kg	min. 100x100 mm max. 600x400 mm	75 kg	2200x2220x370 mm
	VWCA3247-L	42"-47"	200 kg	min. 100x100 mm max. 600x400 mm	100 kg	2200x2930x370 mm
	VWCA3257-L	50"-57"	195 kg	min. 100x100 mm max. 600x400 mm	105 kg	2200x3320x370 mm
	VWCA3347-L	42"-47"	120 kg	min. 100x100 mm max. 600x400 mm	180 kg	2600x2930x370 mm
	VWCA3357-L	50"-57"	125 kg	min. 100x100 mm max. 600x400 mm	175 kg	2600x3320x370 mm
	VWCA2347-L	42"-47"	90 kg	min. 100x100 mm max. 600x400 mm	110 kg	2600x1960x370 mm
	VWCA2357-L	50"-57"	95 kg	min. 100x100 mm max. 600x400 mm	105 kg	2600x2220x370 mm



VWTA Landscape Series - Trolley Video Walls



FEATURES

- Flexible option of mounting multiple screens
- Mobility: 4 freely-rotating casters with individual brakes
- Mounting System: 8-point tool-less micro-adjustment
- VESA Mounting: from 100x100 to 600x400mm

FEATURES PHOTO

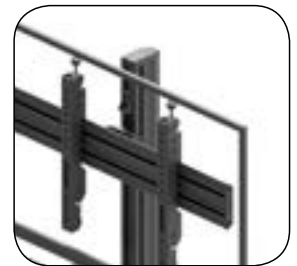

Monitor Configuration	Product	Screen size	Max. capacity	Max. VESA	Weight	Dimensions (HxWxD)
	VWTA2247-L	42"-47"	220 kg	min. 100x100 mm max. 600x400 mm	65 kg	1970x1960x950 mm
	VWTA2257-L	50"-57"	210 kg	min. 100x100 mm max. 600x400 mm	70 kg	1970x2220x950 mm
	VWTA2347-L	42"-47"	205 kg	min. 100x100 mm max. 600x400 mm	85 kg	2570x1960x950 mm
	VWTA2357-L	50"-57"	190 kg	min. 100x100 mm max. 600x400 mm	90 kg	2570x2220x950 mm
	VWTA3247-P	42"-47"	205 kg	min. 100x100 mm max. 600x400 mm	110 kg	2550x820x950 mm
	VWTA3257-L	50"-57"	290 kg	min. 100x100 mm max. 600x400 mm	100 kg	1970x3320x950 mm
	VWTA3347-L	42"-47"	305 kg	min. 100x100 mm max. 600x400 mm	195 kg	2570x2930x950 mm
	VWTA3357-L	50"-57"	290 kg	min. 100x100 mm max. 600x400 mm	135 kg	2570x3320x950 mm



FEATURES

- Screen Layout: 2x2 landscape (a portrait version is also available)
- Mobility: 4 freely-rotating casters with individual brake mechanism
- Mounting System: 8-point tool-less micro-adjustment
- VESA Mounting: from 100x100 to 600x400mm

PRODUCT SPECIFICATION

Dimensions (HxWxD)	Weight	Max capacity
1970x2220x950 mm	70 kg	210 kg



VWSA Landscape Series - Video Wall Stands



FEATURES

- Tool-less independent 8-point micro adjustment provides seamless alignment of the displays
- Universal range of VESA mounts and adapter included
- Flexible option of mounting multiple screens
- Fully height adjustable

FEATURES PHOTO

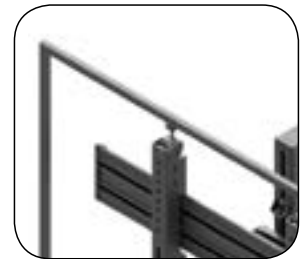
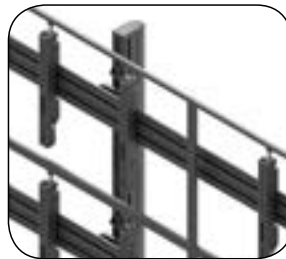

Monitor Configuration	Product	Screen size	Max. capacity	Max. VESA	Weight	Dimensions (HxWxD)
	VWSA2247-L	42-47"	220 kg	min. 100x100 mm max. 600x400 mm	60 kg	1830x1960x350 mm
	VWSA2257-L	50-57"	210 kg	min. 100x100 mm max. 600x400 mm	65 kg	1830x2220x350 mm
	VWSA2347-L	42-47"	205 kg	min. 100x100 mm max. 600x400 mm	80 kg	2430x1960x350 mm
	VWSA2357-L	50-57"	190 kg	min. 100x100 mm max. 600x400 mm	85 kg	2430x2220x350 mm
	VWSA3247-L	42-47"	305 kg	min. 100x100 mm max. 600x400 mm	90 kg	1830x2930x350 mm
	VWSA3257-L	50-57"	290 kg	min. 100x100 mm max. 600x400 mm	95 kg	1830x3320x350 mm
	VWSA3347-L	42-47"	305 kg	min. 100x100 mm max. 600x400 mm	125 kg	2430x2930x350 mm
	VWSA3357-L	50-57"	290 kg	min. 100x100 mm max. 600x400 mm	130 kg	2430x3320x350 mm



FEATURES

- Tool-less independent 8-point micro adjustment provides seamless alignment of the displays
- Universal range of VESA mounts and adapter included
- Flexible option of mounting multiple screens with customized height according to customer's requirements

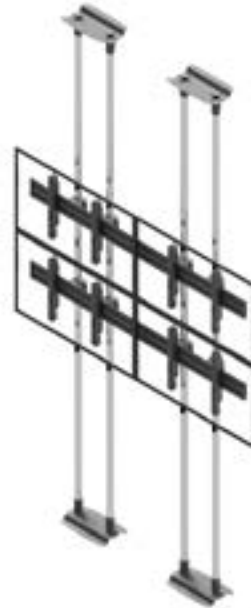

FEATURES PHOTO

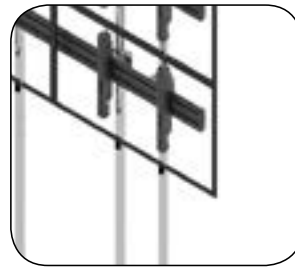
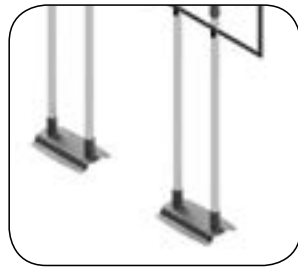
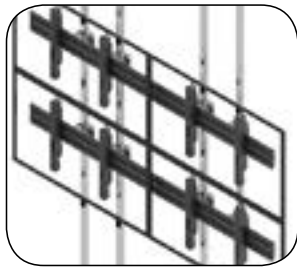

Monitor Configuration	Product	Screen size	Max. capacity	Max. VESA	Weight	Dimensions (HxWxD)
	VWFCA2247-L	42"-47"	220 kg	min. 100x100 mm max. 600x400 mm	85 kg	4000x1960x270 mm
	VWFCA2257-L	50"-57"	210 kg	min. 100x100 mm max. 600x400 mm	90 kg	4000x2220x270 mm
	VWFCA2347-L	42"-47"	220 kg	min. 100x100 mm max. 600x400 mm	100 kg	4000x1960x270 mm
	VWFCA2357-L	50"-57"	210 kg	min. 100x100 mm max. 600x400 mm	105 kg	4000x2220x270 mm
	VWFCA3247-L	42"-47"	210 kg	min. 100x100 mm max. 600x400 mm	125 kg	4000x2930x270 mm
	VWFCA3257-L	50"-57"	330 kg	min. 100x100 mm max. 600x400 mm	130 kg	4000x3320x270 mm
	VWFCA3347-L	42"-47"	330 kg	min. 100x100 mm max. 600x400 mm	150 kg	4000x2930x270 mm
	VWFCA3357-L	50"-57"	310 kg	min. 100x100 mm max. 600x400 mm	150 kg	4000x3320x270 mm



VWCA Portrait Series - Ceiling Video Walls

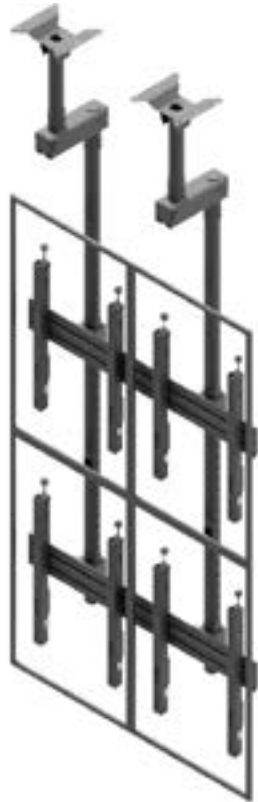

FEATURES

- Tool-less independent 8-point micro adjustment provides seamless alignment of the displays
- Universal range of VESA mounts and adapter included
- Flexible option of mounting multiple screens
- Fully height adjustable

FEATURES PHOTO

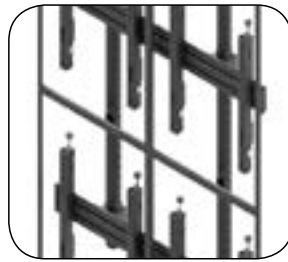

Monitor Configuration	Product	Screen size	Max. capacity	Max. VESA	Weight	Dimensions (HxWxD)
	VWCA2247-P	42"-47"	95 kg	min. 100x100 mm max. 600x400 mm	75 kg	2700x1220x370 mm
	VWCA2257-P	50"-57"	90 kg	min. 100x100 mm max. 600x400 mm	80 kg	2700x1420x370 mm
	VWCA3247-P	42"-47"	110 kg	min. 100x100 mm max. 600x400 mm	90 kg	2600x1960x370 mm
	VWCA3257-P	49"-55"	105 kg	min. 100x100 mm max. 600x400 mm	95 kg	2600x2220x370 mm



**NEW
PRODUCT**

FEATURES

- Tool-less independent 8-point micro adjustment provides seamless alignment of the displays
- Universal range of VESA mounts and adapters included
- Flexible option of mounting multiple screens with customized height according to customer's requirements



FEATURES PHOTO

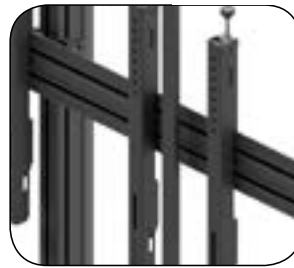
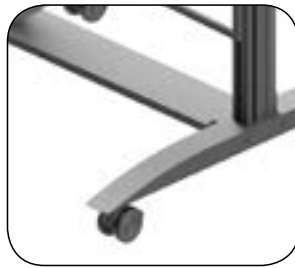

Monitor Configuration	Product	Screen size	Max. capacity	Max. VESA	Weight	Dimensions (HxWxD)
	VWTA2247-P	42"-47"	220 kg	min. 100x100 mm max. 600x400 mm	70 kg	2550x1220x950 mm
	VWTA2257-P	50"-57"	210 kg	min. 100x100 mm max. 600x400 mm	75 kg	2550x1420x950 mm
	VWTA3247-P	42"-47"	205 kg	min. 100x100 mm max. 600x400 mm	110 kg	2550x820x950 mm
	VWTA3257-P	50"-57"	190 kg	min. 100x100 mm max. 600x400 mm	115 kg	2550x2120x950 mm



**NEW
PRODUCT**

FEATURES

- Tool-less independent 8-point micro adjustment provides seamless alignment of the displays
- Universal range of VESA mounts and adapter included
- Flexible option of mounting multiple screens
- Fully height adjustable

FEATURES PHOTO

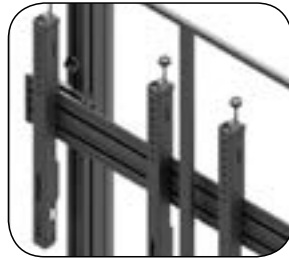

Monitor Configuration	Product	Screen size	Max. capacity	Max. VESA	Weight	Dimensions (HxWxD)
	VWSA2247-P	42"-47"	220 kg	min. 100x100 mm max. 600x400 mm	70 kg	2430x1220x350 mm
	VWSA2257-P	50"-57"	210 kg	min. 100x100 mm max. 600x400 mm	75 kg	2430x1420x350 mm
	VWSA3247-P	42"-47"	205 kg	min. 100x100 mm max. 600x400 mm	100 kg	2430x1820x300 mm
	VWSA3257-P	50"-57"	190 kg	min. 100x100 mm max. 600x400 mm	105 kg	2430x2120x300 mm



FEATURES

- Tool-less independent 8-point micro adjustment provides seamless alignment of the displays
- Universal range of VESA mounts and adapter included
- Flexible option of mounting multiple screens with customized height according to customer's requirements



FEATURES PHOTO

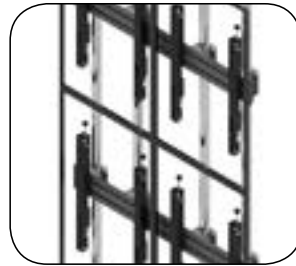
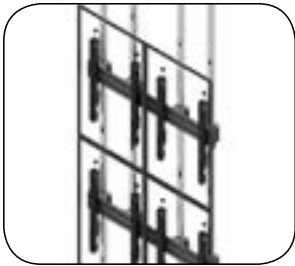

Monitor Configuration	Product	Screen size	Max. capacity	Max. VESA	Weight	Dimensions (HxWxD)
	VWFC A2247-P	42"-47"	220 kg	min. 100x100 mm max. 600x400 mm	85 kg	4000x1220x270 mm
	VWFC A2257-P	50"-57"	210 kg	min. 100x100 mm max. 600x400 mm	90 kg	4000x1420x270 mm
	VWFC A3247-P	42"-47"	330 kg	min. 100x100 mm max. 600x400 mm	130 kg	4000x1800x270 mm
	VWFC A3257-P	50"-57"	310 kg	min. 100x100 mm max. 600x400 mm	135 kg	4000x2100x300 mm



Mobile LED Mounting System

VWLT100

FEATURES

- The new design for quick and easy installation. DIY system
- Structures mobile anchored to the floor, wall and ceiling allow the erection of structures anywhere you need.
- Ability to adapt the design to your individual needs and requirements.
- New cable management system a clean finish and saving space.



PRODUCT SPECIFICATION

Edbak designs innovative products to support and complement the latest LED mounting technologies. Our team stays on the pulse of the AV industry to determine and meet future needs, and supports customers to meet the criteria of individual clients enquiry. We are hire to help to find best solutions. If you need more information about the product please contact with us: sales@edbak.com



Floor-Ceiling LED Mounting System

VWLCF100



FEATURES

- The new design for quick and easy installation. DIY system
- Structures mobile anchored to the floor, wall and ceiling allow the erection of structures anywhere you need.
- Ability to adapt the design to your individual needs and requirements.
- New cable management system a clean finish and saving space.

PRODUCT SPECIFICATION

Edbak designs innovative products to support and complement the latest LED mounting technologies. Our team stays on the pulse of the AV industry to determine and meet future needs, and supports customers to meet the criteria of individual clients enquiry. We are hire to help to find best solutions. If you need more information about the product please contact with us: sales@edbak.com



FEATURES

- The new design for quick and easy installation. DIY system
- Structures mobile anchored to the floor, wall and ceiling allow the erection of structures anywhere you need.
- Ability to adapt the design to your individual needs and requirements.
- New cable management system a clean finish and saving space.

PRODUCT SPECIFICATION

Edbak designs innovative products to support and complement the latest LED mounting technologies. Our team stays on the pulse of the AV industry to determine and meet future needs, and supports customers to meet the criteria of individual clients enquiry. We are hire to help to find best solutions. If you need more information about the product please contact with us: sales@edbak.com



FEATURES

- The new design for quick and easy installation. DIY system
- Structures mobile anchored to the floor, wall and ceiling allow the erection of structures anywhere you need.
- Ability to adapt the design to your individual needs and requirements.
- New cable management system a clean finish and saving space.



PRODUCT SPECIFICATION

Edbak designs innovative products to support and complement the latest LED mounting technologies. Our team stays on the pulse of the AV industry to determine and meet future needs, and supports customers to meet the criteria of individual clients enquiry. We are hire to help to find best solutions. If you need more information about the product please contact with us: sales@edbak.com



Pop-Out Led Video Wall Mounting System

VWLW100

FEATURES

- Universal design – support most LED brands and sizes.
- Suitable for a variety of LED panels and configurations.
- Fast release Pop-Out mechanism extends the mount 1000 millimeters from the wall and allows full service access.
- Pre-assembly of main parts allows quick and easy installation.
- Ability to adapt the design to your individual needs and requirements.
- New cable management system for a clean finish and saving space.



PRODUCT SPECIFICATION

Edbak designs innovative products to support and complement the latest LED mounting technologies. Our team stays on the pulse of the AV industry to determine and meet future needs, and supports customers to meet the criteria of individual clients enquiry. We are here to help to find best solutions. If you need more information about the product please contact with us: sales@edbak.com



Electric Pop-Out Led Video Wall Mounting System

VWLWE100



FEATURES

- New electric mechanism with a free hand system.
- Universal design – support most LED brands and sizes.
- Suitable for a variety of LED panels and configurations.
- Fast release Pop-Out mechanism extends the mount 1000 millimeters from the wall and allows full service access.
- Pre-assembly of main parts allows quick and easy installation.
- Ability to adapt the design to your individual needs and requirements.
- New cable management system for a clean finish and saving space.

PRODUCT SPECIFICATION

Edbak designs innovative products to support and complement the latest LED mounting technologies. Our team stays on the pulse of the AV industry to determine and meet future needs, and supports customers to meet the criteria of individual clients enquiry. We are here to help to find best solutions. If you need more information about the product please contact with us: sales@edbak.com



FLAT PANEL WALL MOUNTS

FEATURES

Level bubble – ensures quick and simple levelling even on uneven walls

Post Installation adjustment – fine correction for height and level for perfect positioning

Tilt adjustment – graduated tilt function allows incremental tilt for ideal viewing angle

Slimline – Ultra low profile design provides seamless integration to the wall

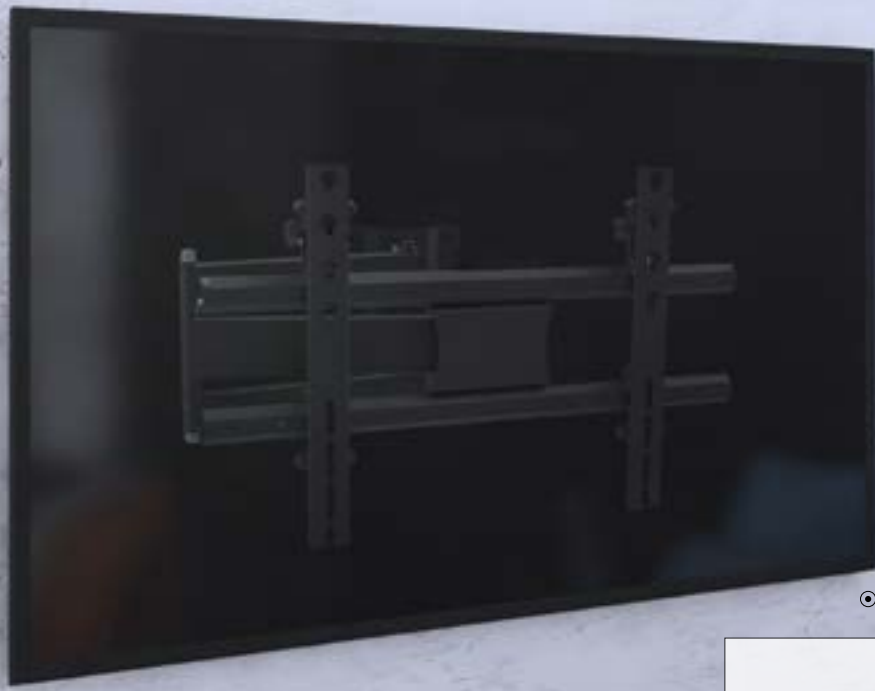

FEATURES

- Universal VESA compatibility
- Adjustable wall extension from 62 to 638 mm
- Slim profile for minimum distance from the wall
- Adjustable Tilt Angle from 0° to 10°
- Security bolts to prevent accidental screen movement

TECHNICAL

min. 200x200 mm
max. 600x400 mm

32"-50"

25 kg

0°/+10°

62-638 mm

90°-90°

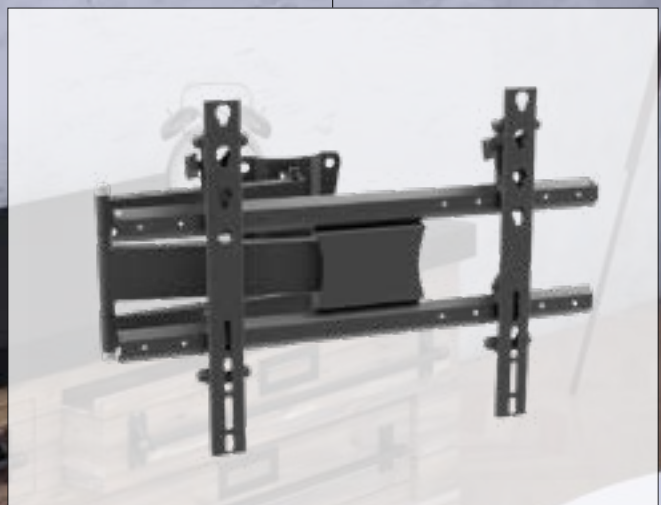

PRODUCT SPECIFICATION

Dimensions (HxWxD)	Weight	Max capacity	Colour	Packaging dimensions
638x660x440 mm	6.8 kg	25 kg	black silver	700x300x80 mm

VSM651

SWING ARM WALL MOUNT



**NEW
PRODUCT**





Swing Arm Wall Mount



FEATURES

- Modern Design with a high-end finish
- Durable aluminum construction with a semi-textured powder coat or anodized finish
- Adjustable wall extension up to 415 mm
- Universal VESA interface suitable for all screens

TECHNICAL

 10°-29°
  230 - 415 mm
  +60°/-60°
  12 kg

 +100°/-100°

min. 75x75 mm
 max. 100x100 mm

PRODUCT SPECIFICATION







Dimensions (HxWxD)	Weight	Max capacity	Colour	Packaging dimensions
120x170x415 mm	2,5 kg	12 kg	black silver	420x170x120 mm

VSM652

FEATURES

- Modern Design with a high-end finish
- Durable aluminum construction with a semi-textured powder coat or anodized finish
- Adjustable wall extension up to 405 mm
- Universal VESA interface suitable for all screens

TECHNICAL

 30°-47°
  105 - 405 mm
  -0°/+11°
  36 kg
  +42°/-42°

min. 100x100mm
 max. 600x400 mm

Swing Arm Wall Mount



**NEW
PRODUCT**



SWING ARM WALL MOUNT

PRODUCT SPECIFICATION

Dimensions (HxWxD)	Weight	Max capacity	Colour	Packaging dimensions
455x720x405 mm	6,5 kg	36 kg	black silver	250x720x100 mm







FEATURES

- Modern Design with a high-end finish
- Durable aluminum construction with a semi-textured powder coat or anodized finish
- Wall plate covers to hide fixings included
- Adjustable wall extension up to 700 mm
- Universal VESA interface suitable for all screens

**NEW
PRODUCT**



TECHNICAL

 30"-47"
  100 - 700 mm
  -0°/+11°
  36 kg
  +62°/-62°

min. 100x100 mm
 max. 600x400 mm

PRODUCT SPECIFICATION

Dimensions (HxWxD)	Weight	Max capacity	Colour	Packaging dimensions
455x720x700 mm	12 kg	36 kg	black silver	140x720x370 mm



SWING ARM WALL MOUNT



FEATURES

- Modern Design with a high-end finish
- Durable aluminum construction with a semi-textured powder coat or anodized finish
- Wall plate covers to hide fixings included
- Adjustable wall extension up to 700 mm
- Universal VESA interface suitable for all screens

TECHNICAL

min. 100x100 mm
max. 600x400 mm

37"-65"

100 - 700 mm

-0°/+11°

+62°/-62°

PRODUCT SPECIFICATION

Dimensions (HxWxD)	Weight	Max capacity	Colour	Packaging dimensions
455x720x700 mm	15,5 kg	45 kg	black silver	140x720x370 mm



FEATURES

- Modern Design with a high-end finish
- Durable aluminum construction with a semi-textured powder coat or anodized finish
- Wall plate covers to hide fixings included
- Adjustable wall extension up to 405 mm
- Universal VESA interface suitable for all screens

TECHNICAL

min. 100x100 mm
max. 600x400 mm

42"-70"

MAX KG
120 kg

0°/90°

min. 100x100 mm
max. 600x460 mm

min. 150mm
max. 800 mm

-10°/+10°



SWING ARM WALL MOUNT

PRODUCT SPECIFICATION

Dimensions (HxWxD)	Weight	Max capacity	Colour	Packaging dimensions
800x980x520 mm	22 kg	120 kg	black silver	1000x350x200 mm

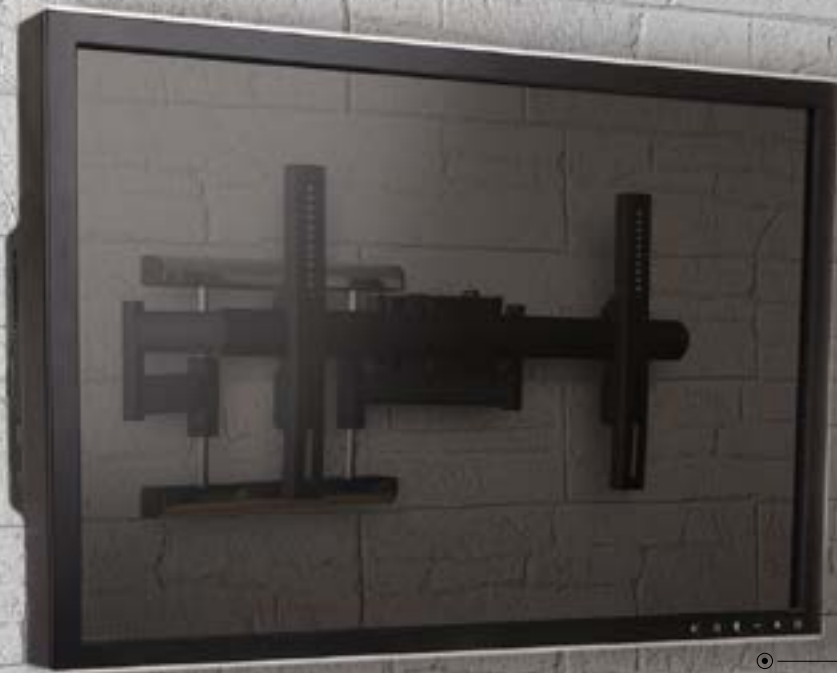

FEATURES

- Universal VESA compatibility
- Adjustable wall extension from 150 to 700 mm
- Supporting heavy displays up to 120 kg
- Adjustable Tilt Angle from -10° to +10°
- Vertical and horizontal position of the screen

PRODUCT SPECIFICATION

Dimensions (HxWxD)	Weight	Max capacity	Colour	Packaging dimensions
700x850x520 mm	25 kg	120 kg	black silver	870x500x200 mm

TECHNICAL



min.
100x100
max.
600x400
mm



42"-90"



120 kg



0°/90°



min.
100x100 mm
max.
600x450
mm



min.
150 mm
max.
700 mm



-10°/+10°

EWB100

26"-40" Fixed Wall Mount



SUPER SLIM FIXED WALL MOUNT



FEATURES

- Universal VESA compatibility
- Slim profile for minimum distance from the wall
- Open frame design for easy wiring and installation access
- Spirit Level allows easy and accurate installation
- Max. capacity 40 kg

TECHNICAL

min. 75x75 mm
max. 400x200 mm

26"-40"

25 mm

min. 60x65 mm
max. 440x337,5 mm

40 kg

PRODUCT SPECIFICATION

Dimensions (HxWxD)	Weight	Max capacity	Colour	Packaging dimensions
495x370x25,5 mm	1,5 kg	40 kg	black silver	500x205x35 mm

EWB200

40"-65" Fixed Wall Mount



FEATURES

- Universal VESA compatibility
- Slim profile for minimum distance from the wall
- Open frame design for easy wiring and installation access
- Spirit Level allows easy and accurate installation
- Max. capacity 40 kg

TECHNICAL

min. 75x75 mm
max. 800x400 mm

40"-65"

25 mm

min. 60x65 mm
max. 825x427,5 mm

40 kg



SUPER SLIM FIXED WALL MOUNT

PRODUCT SPECIFICATION

Dimensions (HxWxD)	Weight	Max capacity	Colour	Packaging dimensions
850x470x25,5 mm	2,3 kg	40 kg	black silver	860x205x35 mm



26"-42" Fixed Wall Mount

LWB1

FEATURES

- Universal VESA compatibility
- Heavy duty 3 mm professional gauge steel
- Security bolts to prevent accidental screen movement
- Max. capacity 60 kg



FIXED WALL MOUNT

TECHNICAL

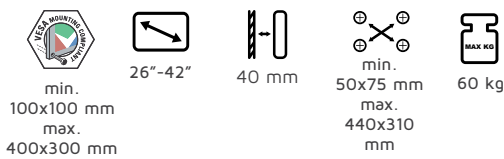

PRODUCT SPECIFICATION

Dimensions (HxWxD)	Weight	Max capacity	Colour	Packaging dimensions
540x260x41 mm	3,1 kg	60 kg	black silver	540x300x45 mm



26"-40" Portrait Wall Mount

LWB3

FIXED WALL MOUNT



FEATURES

- Universal VESA compatibility
- Slim profile for minimum distance from the wall
- Open frame design for easy wiring and installation access
- Spirit Level allows easy and accurate installation
- Max. capacity 40 kg

TECHNICAL

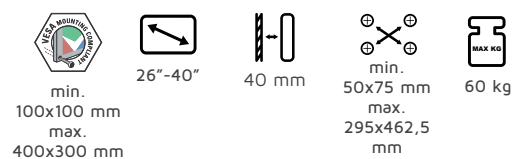

PRODUCT SPECIFICATION

Dimensions (HxWxD)	Weight	Max capacity	Colour	Packaging dimensions
350x490x41 mm	2,6 kg	60 kg	black silver	540x300x45 mm



FIXED WALL MOUNT



FEATURES

- Universal VESA compatibility
- Heavy duty 3 mm professional gauge steel
- Security bolts to prevent accidental screen movement
- Max. capacity 80 kg

TECHNICAL

min. 100x100 mm
max. 600x400 mm

min. 50x95 mm
max. 750x460 mm

42"-60"

80 kg

40 mm

PRODUCT SPECIFICATION

Dimensions (HxWxD)	Weight	Max capacity	Colour	Packaging dimensions
800x500x41 mm	4,7 kg	80 kg	black silver	820x220x38 mm



FEATURES

- Universal VESA compatibility
- Heavy duty 3 mm professional gauge steel
- Security bolts to prevent accidental screen movement
- Max. capacity 80 kg

TECHNICAL

min. 100x100 mm
max. 600x400 mm

42"-60"

45 mm

min. 55x100 mm
max. 400x750 mm

80 kg



FIXED WALL MOUNT

PRODUCT SPECIFICATION

Dimensions (HxWxD)	Weight	Max capacity	Colour	Packaging dimensions
458x780x44,6 mm	7 kg	80 kg	black silver	790x350x75 mm



65"-75" Fixed Wall Mount

TWB1

FEATURES

- Universal VESA compatibility
- Heavy duty 3 mm professional gauge steel
- Security bolts to prevent accidental screen movement
- Max. capacity 80 kg

TECHNICAL

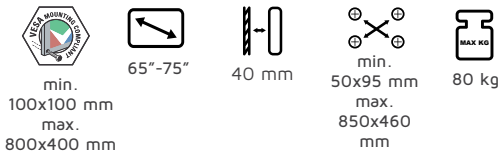

FIXED WALL MOUNT

PRODUCT SPECIFICATION

Dimensions (HxWxD)	Weight	Max capacity	Colour	Packaging dimensions
900x500x48,5 mm	5,3 kg	80 kg	black silver	910x220x40 mm



65"-75" Portrait Wall Mount

TWB3

FIXED WALL MOUNT



FEATURES

- Universal VESA compatibility
- Heavy duty 3 mm professional gauge steel
- Security bolts to prevent accidental screen movement
- Max. capacity 60 kg

TECHNICAL

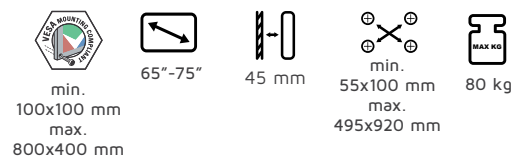

PRODUCT SPECIFICATION

Dimensions (HxWxD)	Weight	Max capacity	Colour	Packaging dimensions
550x950x44,6 mm	9,8 kg	80 kg	black silver	1280x320x60 mm







FIXED WALL MOUNT



FEATURES

- Universal VESA compatibility
- Heavy duty 3 mm professional gauge steel
- Security bolts to prevent accidental screen movement
- Max. capacity 110 kg

TECHNICAL

min. 200x200 mm
 max. 1200x600 mm

80"-95"

42 mm

min. 100x125 mm
 max. 1200x600 mm

110 kg

PRODUCT SPECIFICATION





Dimensions (HxWxD)	Weight	Max capacity	Colour	Packaging dimensions
1260x540x42 mm	11,3 kg	110 kg	black silver	1280x320x60 mm



FEATURES

- Universal VESA compatibility
- Heavy duty 3 mm professional gauge steel
- Security bolts to prevent accidental screen movement
- Max. capacity 80 kg

TECHNICAL

min. 100x200 mm
 max. 1200x400 mm

80"-95"

40 mm

min. 100x200 mm
 max. 510x1200 mm

80 kg



FIXED WALL MOUNT

PRODUCT SPECIFICATION

Dimensions (HxWxD)	Weight	Max capacity	Colour	Packaging dimensions
600x1245x41 mm	9,8 kg	80 kg	black silver	1280x320x60 mm



40"-65" Tilt Wall Mount

EWB250

FEATURES

- Universal VESA compatibility
- Slim profile for minimum distance from the wall
- Adjustable Tilt Angle from 0° to 12°
- Open frame design for easy wiring and installation access
- Spirit Level allows easy and accurate installation



TILTING WALL MOUNTS

TECHNICAL

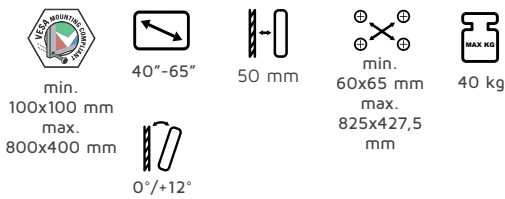

PRODUCT SPECIFICATION

Dimensions (HxWxD)	Weight	Max capacity	Colour	Packaging dimensions
850x470x48,75 mm	2,65 kg	40 kg	black silver	860x205x65 mm



26"-40" Tilt Wall Mount

LWB2

TILTING WALL MOUNTS

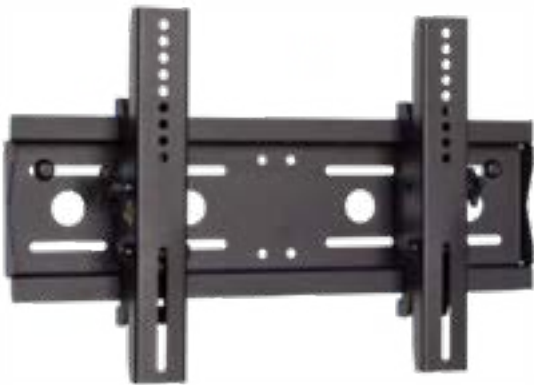

FEATURES

- Security bolts to prevent accidental screen movement
- Adjustable Tilt Angle included from 6,5° to 12°
- Heavy duty 3 mm professional gauge steel
- Max. capacity 80 kg

TECHNICAL

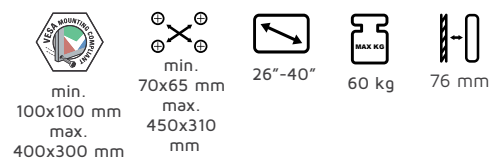

PRODUCT SPECIFICATION

Dimensions (HxWxD)	Weight	Max capacity	Colour	Packaging dimensions
350x490x41 mm	2,6 kg	60 kg	black silver	540x300x45 mm



FEATURES

- Security bolts to prevent accidental screen movement
- Adjustable Tilt Angle included from 6,5° to 12°
- Heavy duty 3 mm professional gauge steel
- Max. capacity 80 kg

PRODUCT SPECIFICATION

Dimensions (HxWxD)	Weight	Max capacity	Colour	Packaging dimensions
800x500x77,4 mm	5,5 kg	80 kg	black silver	805x220x80 mm

TECHNICAL

min. 100x100 mm max. 600x400 mm	42"-60"	80 kg	min. 70x95 mm max. 740x460 mm	-6,5°/+12° 77,4 mm



60"-75" Tilt Wall Mount

TWB2

FEATURES

- Universal VESA compatibility
- Security bolts to prevent accidental screen movement
- Adjustable Tilt Angle included from 6° to 11°
- Heavy duty 3 mm professional gauge steel
- Max. capacity 80 kg



TILTING WALL MOUNTS

TECHNICAL

min. 100x100 mm
max. 800x400 mm

60"-75"

77,4 mm

min. 70x95 mm
max. 845x460 mm

80 kg

-6°/+11°

PRODUCT SPECIFICATION

Dimensions (HxWxD)	Weight	Max capacity	Colour	Packaging dimensions
910x220x75 mm	6,5 kg	80 kg	black silver	910x220x75 mm



32"-47" Tilt Wall Mount

CMLS2

FLAT SCREEN CEILING MOUNTSS



FEATURES

- Universal range of VESA mounting options
- Telescopic mounting - with flexible height adjustment
- Distance from the ceiling to the screen 1332 to 1770 mm
- Internal cable management in pole
- Adjustable tilt angle from 0° to 22° of the screen

TECHNICAL

min. 100x100 mm
max. 600x400 mm

32"-47"

30 kg

90°/90°

min. 70x95 mm
max. 740x460 mm

min. 1332 mm
max. 1770 mm

-0°/+22°

PRODUCT SPECIFICATION

Dimensions (HxWxD)	Weight	Max capacity	Colour	Packaging dimensions
1170x800x183 mm	12,7 kg	30 kg	black silver	1000x300x150 mm



FEATURES

- Universal range of VESA mounting options
- Telescopic mounting - with flexible height adjustment
- Distance from the ceiling to the screen 1375 to 2175 mm
- Internal cable management in pole
- Adjustable tilt angle from 0° to 22°

PRODUCT SPECIFICATION

Dimensions (HxWxD)	Weight	Max capacity	Colour	Packaging dimensions
2175x800x200 mm	12 kg	60 kg	black silver	1310x210x210 mm

TECHNICAL



min.
100x100
max.
600x400
mm



37"-65"



60 kg



90°/90°



min.
50x95 mm
max.
750x460
mm



min.
1375 mm
max.
2175 mm



32"-65" LCD Ceiling Mount

CMS1

FEATURES

- Universal range of VESA mounting options
- Distance from the ceiling to the screen 1677 mm
- Internal cable management in pole
- Adjustable tilt angle from 12,5° to 6,5°
- Tubular chrome pole luxury finish

TECHNICAL

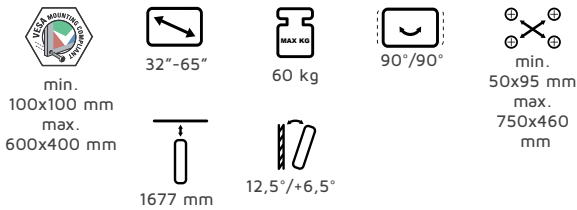

FLAT SCREEN CEILING MOUNTS

PRODUCT SPECIFICATION

Dimensions (HxWxD)	Weight	Max capacity	Colour	Packaging dimensions
1677x800x200 mm	14,2 kg	60 kg	black silver	1310x210x210 mm



32"-65" Adjustable Ceiling Mount

CMS2

FLAT SCREEN CEILING MOUNTSS



FEATURES

- Universal range of VESA mounting options
- Telescopic mounting - with flexible height adjustment
- Distance from the ceiling to the screen 1332 to 1770 mm
- Internal cable management in pole
- Adjustable tilt angle from 0° to 22° of the screen

TECHNICAL

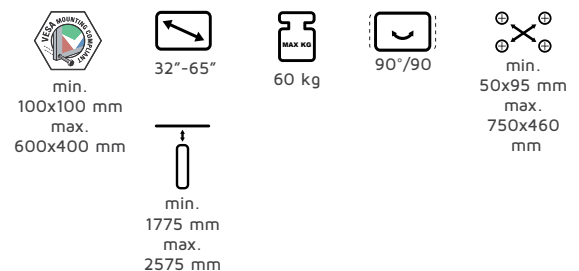

PRODUCT SPECIFICATION

Dimensions (HxWxD)	Weight	Max capacity	Colour	Packaging dimensions
1775x800x200 mm	19,7 kg	60 kg	black silver	1310x210x210 mm



FLAT SCREEN CEILING MOUNTS



PRODUCT SPECIFICATION

Dimensions (HxWxD)	Weight	Max capacity	Colour	Packaging dimensions
1450x800x326 mm	25,4 kg	120 kg	black silver	1310x210x210 mm

FEATURES

- Universal range of VESA mounting options
- Allows multiple installation of 2 screens
- Telescopic mounting - with flexible height adjustment
- Distance from the ceiling to the screen 1375 to 2175 mm
- Internal cable management in pole

TECHNICAL



FEATURES

- Universal range of VESA mounting options
- Fully height adjustable
- 360° rotation for portrait or horizontal screen option
- Adjustable tilt angle from 0° to 40°
- Allows dual mounting options: through desk and edge of desk

TECHNICAL



SCREEN DESK MOUNT

PRODUCT SPECIFICATION

Dimensions (HxWxD)	Weight	Max capacity	Colour	Packaging dimensions
405x220x120,5 mm	4 kg	15 kg	black silver	520x240x130 mm



FEATURES

- Universal range of VESA mounting options
- Fully height adjustable
- 360° rotation for portrait or horizontal screen option
- Adjustable tilt angle from 0° to 40°
- Allows dual mounting options: through desk and edge of desk

TECHNICAL

min. 75x75 mm
max. 200x200 mm

32"-46"

MAX KG
15 kg

360°

min. 75x75 mm
max. 200x200 mm

100-660 mm

40°

360°



SCREEN DESK MOUNT

PRODUCT SPECIFICATION

Dimensions (HxWxD)	Weight	Max capacity	Colour	Packaging dimensions
705x220x120,5 mm	5,5 kg	15 kg	black silver	820x240x130 mm

ACCESSORIES

CMARM60 Decorative finishing ring for ceiling mounts

Colour	Packaging dimensions
black grey	1800x360x140 mm





MENU BOARDS

FEATURES

Modular – purpose designed for flexibility, future updates and ease of installation

Tilt – enables simple and exacting multi screen alignment

Adjustment – post installation adjustment allows free movement of screens and fine alignment

Security – security lock feature and optional lock kit for secure engagement in public areas

MBV Series - Menu Board for 42"-57" Screens, Landscape



FEATURES

- Universal range of VESA mounting options
- Allows a multiple installation from 1 to 3 screens
- Internal cable management in a pole tube
- Adjustable tilt angle from 0° to +18°
- Construction up to 210 kg of capacity

TECHNICAL



Monitor configuration	Product	Screen size	Max. capacity	Max. VESA	Weight	Dimensions (HxWxD)
	MB1155-L	42"-57"	70 kg	min. 100x100 mm max. 600x400 mm	13,5 kg	1370x720x250 mm
	MBV2147-L	42"-47"	140 kg	min. 100x100 mm max. 600x400 mm	26 kg	1370x1960x250 mm
	MBV2155-L	50"-57"	140 kg	min. 100x100 mm max. 600x400 mm	28 kg	1370x2200x250 mm
	MBV3147-L	42"-47"	210 kg	min. 100x100 mm max. 600x400 mm	42 kg	1370x2930x250 mm
	MBV3155-L	50"-57"	210 kg	min. 100x100 mm max. 600x400 mm	44 kg	1370x3320x250 mm



FEATURES

- Universal range of VESA mounting options
- Allows a multiple installation from 1 to 2 screens
- Internal cable management in a pole tube
- Adjustable tilt angle from 0° to +18°
- Construction up to 140 kg of capacity



TECHNICAL



min.
100x100 mm
max.
600x400 mm



42"-57"



0°/+18



min.
50x75 mm
max.
750x460 mm



140 kg



min.225 mm
max.1125mm

MENU BOARDS

Monitor configuration	Product	Screen size	Max. capacity	Max. VESA	Weight	Dimensions (HxWxD)
	MBV1155-P	42"-57"	70 kg	min. 100x100 mm max. 600x400 mm	15 kg	1470x500x250 mm
	MBV2147-P	42"-47"	140 kg	min. 100x100 mm max. 600x400 mm	27 kg	1470x500x250 mm
	MBV2155-P	50"-57"	140 kg	min. 100x100 mm max. 600x400 mm	29 kg	1470x1200x250 mm

MBV Series - Menu Board for 42"-57" Back-to-back Screens, Landscape









FEATURES



- Universal range of VESA mounting options
- Allows a multiple installation from 1 to 3 screens
- Internal cable management in a pole tube
- Adjustable tilt angle from 0° to +18°
- Construction up to 210 kg of capacity



TECHNICAL

min. 100x100 mm
 max. 600x400 mm
 42"-57"
 0°/+18°
 min. 50x75 mm
 max. 750x460 mm
 210 kg
 min. 225 mm
 max. 1125mm

Monitor configuration	Product	Screen size	Max. capacity	Max. VESA	Weight	Dimensions (HxWxD)
	MBV1155BB-L	42"-57"	70 kg	min. 100x100 mm max. 600x400 mm	36 kg	1370x1960x250 mm
	MBV2147BB-L	42"-47"	140 kg	min. 100x100 mm max. 600x400 mm	36 kg	1370x1960x250 mm
	MBV2155BB-L	50"-57"	140 kg	min. 100x100 mm max. 600x400 mm	38 kg	1370x2200x250 mm
	MBV3147BB-L	42"-47"	210 kg	min. 100x100 mm max. 600x400 mm	57 kg	1370x2930x250 mm
	MBV3155BB-L	50"-57"	210 kg	min. 100x100 mm max. 600x400 mm	59 kg	1370x3320x250 mm

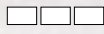
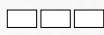

FEATURES

- Universal range of VESA mounting options
- Allows a multiple installation from 1 to 2 screens
- Internal Cable management in a pole tube
- Adjustable tilt angle from 0° to +18°
- Construction up to 140 kg of capacity

TECHNICAL



min.
100x100 mm
max.
600x400 mm



42"-57"



0°/+18



min.
50x75 mm
max.
750x460 mm





140 kg

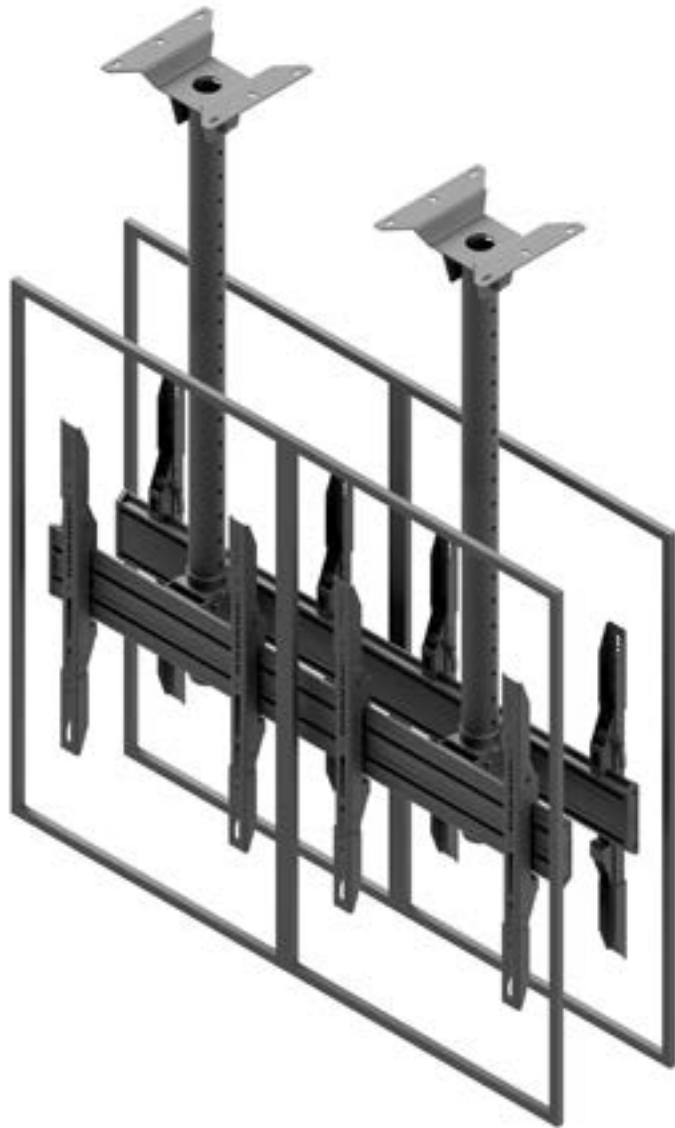

min.225 mm
max.1125mm



MENU BOARDS

Monitor configuration	Product	Screen size	Max. capacity	Max. VESA	Weight	Dimensions (HxWxD)
	MBV1155BB-P	42"-57"	70 kg	min. 100x100 mm max. 600x400 mm	35 kg	1470x500x250 mm
	MBV2147BB-P	42"-47"	140 kg	min. 100x100 mm max. 600x400 mm	48 kg	1470x1000x250 mm
	MBV2155BB-P	50"-57"	140 kg	min. 100x100 mm max. 600x400 mm	50 kg	1470x1200x251 mm



42"-55" Menu Board for 1 screen, multiscreens configuration wall mount, Landscape

MBV155W-L

FEATURES

- Universal range of VESA mounting options
- Allows multiple installation
- Adjustable tilt angle from 0° to +18°
- Certificated for public use installation
- Heavy-duty design

TECHNICAL



min.
100x100 mm
max.
600x400 mm



42"-55"



0°/+18°



min.
50x75 mm
max.
750x460 mm



60 kg



MENU BOARDS

PRODUCT SPECIFICATION

Dimensions (HxWxD)	Weight	Colour
470x1000x65	5 kg	black



42"-55" Ceiling Menu Board for 4 screens, Landscape

MBV455Q-L

FEATURES

- Universal range of VESA mounting options
- Allows a multiple installation of 4 screens
- Internal cable management in a pole tube
- Adjustable tilt angle from 0° to +18°
- Construction up to 240 kg of capacity

TECHNICAL



min.
100x100 mm
max.
600x400 mm



42"-55"



0°/+18°



min.
50x75 mm
max.
750x460 mm



70 kg



min. 610 mm
max. 1460 mm

PRODUCT SPECIFICATION

Dimensions (HxWxD)	Weight	Colour
1600x1240x1240 mm	42 kg	black

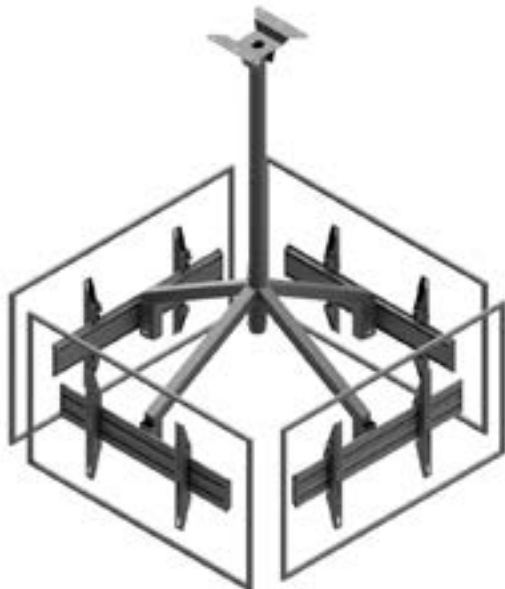

MENU BOARDS



FEATURES

- Universal range of VESA mounting options
- Allows a multiple installation of 3 screens
- Internal cable management in a pole tube
- Adjustable tilt angle from 0° to +18°
- Construction up to 180 kg of capacity

TECHNICAL

min. 100x100 mm
max. 600x400 mm

42"-55"

0°/+18°

min. 50x75 mm
max. 400x260 mm

70 kg

min. 500 mm
max. 1350 mm

PRODUCT SPECIFICATION

Dimensions (HxWxD)	Weight	Colour
1600x900x900 mm	30 kg	black



42"-55" Ceiling Menu board for 4 screens, back-to-back, Landscape

MBV455BBS-L

FEATURES

- Universal range of VESA mounting options
- Allows a multiple installation of 4 screens
- Internal cable management in a pole tube
- Adjustable tilt angle from 0° to +18°
- Construction up to 240 kg of capacity

TECHNICAL



min.
100x100 mm
max.
600x400 mm



42"-55"



0°/+18°



min.
50x75 mm
max.
750x460 mm



100 kg



1270 mm



MENU BOARDS

PRODUCT SPECIFICATION

Dimensions (HxWxD)	Weight	Colour
470x1000x65 mm	30 kg	black



MONITOR MOUNTS

FEATURES

Full range options – including desk, wall and ceiling designs

Ergonomic – space saving solutions with ergonomic features

VESA – compatibility with monitors from 75x75 to 200x200

Adjustment – fully adjustable including height, tilt and swivel



19"-27" Monitor Fixed Wall Mount

GD22

FEATURES

- Slim profile for minimum distance from the wall
- Heavy duty 3 mm professional gauge steel
- Easy and simple installation in just 3 steps

TECHNICAL



min.
75x75 mm
max.
100x100 mm



19"-27"



10 kg



18 mm



min.
75x75 mm
max.
100x100 mm



WALL MONITOR MOUNTS

PRODUCT SPECIFICATION

Dimensions (HxWxD)	Weight	Max capacity	Colour	Packaging dimensions
201,5x150x18 mm	1 kg	10 kg	black silver	160x225x20 mm



19"-27" Monitor Swing Arm Wall Mount

GD01

WALL MONITOR MOUNTS



FEATURES

- Increased flexibility of 2 axis of rotation
- 360° rotation for portrait or horizontal screen option
- Under arm cable management

TECHNICAL



min.
75x75 mm
max.
100x100 mm



19"-27"



10 kg



110°/110°



min.
75x75 mm
max.
100x100 mm



min. 108 mm
max. 472 mm



180°



360°

PRODUCT SPECIFICATION

Dimensions (HxWxD)	Weight	Max capacity	Colour	Packaging dimensions
783x800x500 mm	9,3 kg	10 kg	black silver	810x280x950 mm



WALL MONITOR MOUNTS



FEATURES

- Increased flexibility of 2 axis of rotation
- 360° rotation for portrait or horizontal screen option
- Under arm cable management

TECHNICAL



min.
75x75 mm
max.
100x100 mm



19"-27"



10 kg



110°/110°



min.
75x75 mm
max.
100x100 mm



min.
108 mm
max.
307 mm



180°



360°

PRODUCT SPECIFICATION

Dimensions (HxWxD)	Weight	Max capacity	Colour	Packaging dimensions
307x178x115 mm	2.5 kg	10 kg	black silver	425x250x100 mm



FEATURES

- Slim profile for minimum distance from the wall
- 360° rotation for portrait or horizontal screen option
- Easy and simple installation in just 3 steps

TECHNICAL



min.
75x75 mm
max.
100x100 mm



19"-27"



10 kg



360°



min.
75x75 mm
max.
100x100 mm



25 mm



WALL MONITOR MOUNTS

PRODUCT SPECIFICATION

Dimensions (HxWxD)	Weight	Max capacity	Colour	Packaging dimensions
115x115x25 mm	0.55 kg	10 kg	black silver	135x135x55 mm



FEATURES

- 360° rotation for portrait or horizontal screen option
- Adjustable Tilt Angles included from 180°
- Includes security screw-theft-protection
- Easy and simple installation in just 3 steps

TECHNICAL

 min. 75x75 max. 100x100 mm	 19°-27°	 MAX KG 10 kg	 106 mm
 110°/110°	 180°	 360°	 min. 75x75 mm max. 100x100 mm



PRODUCT SPECIFICATION

Dimensions (HxWxD)	Weight	Max capacity	Colour	Packaging dimensions
115x115x106 mm	0.8 kg	10 kg	black silver	115x120x120 mm



WALL MONITOR MOUNTS



FEATURES

- Slim profile for minimum distance from the wall
- 360° rotation for portrait or horizontal screen option
- Easy and simple installation in just 2 steps

TECHNICAL

min. 75x75 mm
max. 100x100 mm

19"-27"

10 kg

110°/110°

min. 75x75 mm
max. 100x100 mm

124 mm

140°

360°

PRODUCT SPECIFICATION

Dimensions (HxWxD)	Weight	Max capacity	Colour	Packaging dimensions
174x126x124 mm	1.1 kg	10 kg	black silver	200x140x140 mm



FEATURES

- 360° rotation for portrait or horizontal screen option
- Adjustable Tilt Angles included from 145°
- Easy and simple installation in just 2 steps

TECHNICAL

min. 75x75 mm
max. 100x100 mm

19"-27"

10 kg

110°/110°

min. 75x75 mm
max. 100x100 mm

91 mm

145°

360°

PRODUCT SPECIFICATION

Dimensions (HxWxD)	Weight	Max capacity	Colour	Packaging dimensions
115x115x91 mm	1.1 kg	10 kg	black silver	200x140x140 mm

WALL MONITOR MOUNTS



FEATURES

- Adjustable wall extension from 108 to 792 mm
- Increased flexibility of 3 axis of rotation
- 360° rotation for portrait or horizontal screen option
- Under arm cable management

TECHNICAL

min. 19"-27"
max. 100x100 mm

10 kg

110°/110°

min. 108 mm
max. 792 mm

180°

360°

min. 75x75 mm
max. 100x100 mm

PRODUCT SPECIFICATION

Dimensions (HxWxD)	Weight	Max capacity	Colour	Packaging dimensions
792x219x115 mm	2.5 kg	10 kg	black silver	425x250x100 mm





WALL MONITOR MOUNTS



FEATURES

- Adjustable wall extension from 108 to 600 mm
- Increased flexibility of 3 axis of rotation
- 360° rotation for portrait or horizontal screen option
- Under arm cable management

TECHNICAL

PRODUCT SPECIFICATION

Dimensions (HxWxD)	Weight	Max capacity	Colour	Packaging dimensions
600x238x147 mm	3.7 kg	10 kg	black silver	425x250x100 mm



FEATURES

- 360° rotation for portrait or horizontal screen option
- Complete vertical and horizontal adjustability
- Allows dual mounting options: through desk or edge of desk
- Easy and simple installation in just 2 steps

TECHNICAL



DESK MONITOR MOUNTS

PRODUCT SPECIFICATION

Dimensions (HxWxD)	Weight	Max capacity	Colour	Packaging dimensions
405x125x700 mm	4.9 kg	10 kg	black silver	480x375x130 mm



19"-27" Desk Mount

SV03

FEATURES

- Adjustable arm length - from 10 to 700 mm
- 360° rotation for portrait or horizontal screen option
- Complete vertical and horizontal adjustability
- Allows dual mounting options: through desk or edge of desk



DESK MONITOR MOUNTS

TECHNICAL

min. 75x75 mm
max. 100x100 mm

19"-27"

10 kg

360°

min. 75x75 mm
max. 100x100 mm

160°

360°

min. 100 mm
max. 405 mm

PRODUCT SPECIFICATION

Dimensions (HxWxD)	Weight	Max capacity	Colour	Packaging dimensions
405x125x700 mm	4.9 kg	10 kg	black silver	480x375x130 mm



19"-27" Slim Pole Desk Mount

SV29

DESK MONITOR MOUNTS



FEATURES

- Distance from desk to the screen 530 mm to 875 mm
- Adjustable Tilt Angle included from 90° to 30° degrees
- Allows dual mounting options: through desk and edge of desk

TECHNICAL

min. 75x75 mm
max. 100x100 mm

19"-27"

10 kg

360°

min. 75x75 mm
max. 100x100 mm

90°/-30°

min. 530 mm
max. 875 mm

PRODUCT SPECIFICATION

Dimensions (HxWxD)	Weight	Max capacity	Colour	Packaging dimensions
875x125x45 mm	2.2 kg	10 kg	black silver	540x130x120 mm

FEATURES

- Adjustable arm length - from 10 to 528 mm
- 360° rotation for portrait or horizontal screen option
- Complete vertical and horizontal adjustability
- Allows dual mounting options: through desk or edge of desk

TECHNICAL



min.
75x75
max.
100x100
mm

19"-27"

10 kg

90°/90°

min.
75x75 mm
max.
100x100 mm

250°

360°

PRODUCT SPECIFICATION

Dimensions (HxWxD)	Weight	Max capacity	Colour	Packaging dimensions
405x125x528 mm	4.4 kg	10 kg	black silver	520x170x130 mm





19"-27" Slim Pole Desk Mount

SV30

FEATURES

- Distance from desk to the screen 530 mm to 875 mm
- Adjustable Tilt Angle included from 90° to 30° degrees
- Allows dual mounting options: through desk and edge of desk

TECHNICAL



min.
75x75 mm
max.
100x100 mm

19"-27"

10 kg

360°

min.
75x75 mm
max.
100x100 mm

min.
280 mm
max.
450 mm

90°/-30°



DESK MONITOR MOUNTS

PRODUCT SPECIFICATION

Dimensions (HxWxD)	Weight	Max capacity	Colour	Packaging dimensions
405x125x366 mm	2 kg	10 kg	black silver	340x130x120 mm



19"-27" Swing Arm Wall Mount

MSA02

MEDICAL MONITOR MOUNTS



FEATURES

- Distance from the wall to screen up to 1610 mm
- Professional gas spring loaded for smooth vertical adjustment
- Increased flexibility of 3 axis of rotation
- 360° rotation for portrait or horizontal screen option
- Full cable management

TECHNICAL

min.
75x75 mm
max.
100x100 mm

19"-27"

10 kg

360°

min.
75x75 mm
max.
100x100 mm

22,5°/-22,5°

360°

PRODUCT SPECIFICATION

Dimensions (HxWxD)	Weight	Max capacity	Colour	Packaging dimensions
1610x884x160 mm	12 kg	10 kg	black silver white	1080x650x220 mm



FEATURES

- Distance from the ceiling to screen 1593 mm to 2545 mm
- Professional gas spring loaded for smooth vertical adjustment
- Increased flexibility of 3 axis of rotation
- 360° rotation for portrait or horizontal screen option
- Full cable management

PRODUCT SPECIFICATION

Dimensions (HxWxD)	Weight	Max capacity	Colour	Packaging dimensions
1744x2545x2490 mm	23 kg	10 kg	black silver white	1050x620x350 mm

TECHNICAL



min.
75x75
max.
100x100
mm



19"-27"



10 kg



360°



min.
75x75 mm
max.
100x100 mm



22,5/-22,5°



360°



19"-27" Desk Mount for 2 Screens

SV05

FEATURES

- Flexible option of mounting 2 screens
- 360° rotation for portrait or horizontal screen option
- Allows dual mounting options: through desk and edge of desk
- Easy and simple installation in just 2 steps

TECHNICAL

min. 75x75 mm max. 100x100 mm

19"-27"

20 kg

360°

min. 75x75 mm max. 100x100 mm

160°

360°

min. 100 mm max. 405 mm



DESK MONITOR MOUNTS

PRODUCT SPECIFICATION

Dimensions (HxWxD)	Weight	Max capacity	Colour	Packaging dimensions
405x750x107 mm	4.9 kg	20 kg	black silver	650x210x160 mm



19"-27" Swing Arm Desk Mount for 2 Screens

SV06

DESK MONITOR MOUNTS



FEATURES

- Flexible option of mounting 2 screens
- Adjustable arm length - from 10 to 525 mm
- Allows dual mounting options: through desk and edge of desk
- Easy and simple installation in just 2 steps

TECHNICAL

min. 75x75 mm max. 100x100 mm

19"-27"

20 kg

360°

min. 75x75 mm max. 100x100 mm

150°

360°

min. 100 mm max. 405 mm

PRODUCT SPECIFICATION

Dimensions (HxWxD)	Weight	Max capacity	Colour	Packaging dimensions
405x1050x107 mm	6.8 kg	20 kg	black silver	560x220x140 mm

FEATURES

- Flexible option of mounting 4 screens
- Complete vertical and horizontal adjustability
- Allows dual mounting options: through desk or edge of desk
- Easy and simple installation in just 2 steps

TECHNICAL



min.
75x75 mm
max.
100x100 mm



19"-27"



40 kg



360°



min.
75x75 mm
max.
100x100 mm



160°



360°



PRODUCT SPECIFICATION

Dimensions (HxWxD)	Weight	Max capacity	Colour	Packaging dimensions
705x750x107 mm	7.5 kg	40 kg	black silver	820x190x120 mm



19"-27" Dual Monitor Desk Mount

SV08

FEATURES

- 360° rotation for portrait or horizontal screen option
- Complete vertical and horizontal adjustability
- Allows dual mounting options: through desk and edge of desk
- Easy and simple installation in just 2 steps

TECHNICAL

min. 75x75 mm
max. 100x100 mm

19"-27"

MAX KG
20 kg

360°

min. 75x75 mm
max. 100x100 mm

250°

360°

min. 100 mm
max. 705 mm



DESK MONITOR MOUNTS

PRODUCT SPECIFICATION

Dimensions (HxWxD)	Weight	Max capacity	Colour	Packaging dimensions
705x125x116 mm	4.9 kg	20 kg	black silver	820x190x120 mm



19"-27" Triple Monitor Desk Mount

SV10

FEATURES

- Flexible option for mounting 3 screens
- 360° rotation for portrait or horizontal screen option
- Complete vertical and horizontal adjustability
- Allows dual mounting options: through desk and edge of desk

TECHNICAL

min. 75x75 mm
max. 100x100 mm

19"-27"

MAX KG
30 kg

360°

min. 75x75 mm
max. 100x100 mm

160°

360°

PRODUCT SPECIFICATION

Dimensions (HxWxD)	Weight	Max capacity	Colour	Packaging dimensions
405x1400x108 mm	9.7 kg	30 kg	black silver	1450x210x170 mm



DESK MONITOR MOUNTS



DESK MONITOR MOUNTS

FEATURES

- Flexible option for mounting 3 screens
- Allows Parabolic layout of displays for Ergonomic solution
- Complete vertical and horizontal adjustability
- Allows dual mounting options: through desk and edge of desk



TECHNICAL



min.
75x75 mm
max.
100x100 mm



19"-27"



30 kg



210°



min.
75x75 mm
max.
100x100 mm



160°



360°



min.
100 mm
max.
405 mm

PRODUCT SPECIFICATION

Dimensions (HxWxD)	Weight	Max capacity	Colour	Packaging dimensions
405x1490x108 mm	10.5 kg	30 kg	black silver	1520x210x170 mm



FEATURES

- Flexible option of mounting 6 screens
- Under arm cable management
- Complete vertical and horizontal adjustability
- Allows dual mounting options: through desk and edge of desk



DESK MONITOR MOUNTS

TECHNICAL



min.
75x75 mm
max.
100x100 mm



19"-27"



60 kg



210°



min.
75x75 mm
max.
100x100 mm



160°



360°



min.
100 mm
max.
705 mm

PRODUCT SPECIFICATION

Dimensions (HxWxD)	Weight	Max capacity	Colour	Packaging dimensions
705x1400x108 mm	14.5 kg	60 kg	black silver	1300x210x170 mm



19"-27" Curved Desk Mount for 6 Screens

SV17

FEATURES

- Flexible option of mounting 6 screens
- Allows Parabolic layout of displays for Ergonomic solution
- Complete vertical and horizontal adjustability
- Allows dual mounting options: through desk and edge of desk



DESK MONITOR MOUNTS

TECHNICAL

min. 75x75 mm
max. 100x100 mm

19"-27"

60 kg

210°

min. 75x75 mm
max. 100x100 mm

160°

360°

PRODUCT SPECIFICATION

Dimensions (HxWxD)	Weight	Max capacity	Colour	Packaging dimensions
705x1490x108 mm	14.5 kg	60 kg	black silver	1300x330x220 mm



19"-27" Under Shelf Monitor Mount

USM1

UNDERSHELF MONITOR MOUNTS



FEATURES

- Optional under shelf assembly
- Adjustable tilt angle from 12° to 90°
- 360° rotation for portrait or horizontal screen option
- Easy and simple installation in just 2 steps

TECHNICAL

min. 75x75 mm
max. 100x100 mm

19"-27"

10 kg

299 mm

min. 75x75 mm
max. 100x100 mm

12°/ 90°

360°

PRODUCT SPECIFICATION

Dimensions (HxWxD)	Weight	Max capacity	Colour	Packaging dimensions
1610x884x160 mm	12 kg	10 kg	black silver white	1080x650x220 mm



CEILING MONITOR MOUNTS



FEATURES

- Distance from the ceiling to the screen up to 730 mm
- 360° full Horizontal adjustment
- Adjustable tilt angle 120°
- Max. capacity 10 kg

TECHNICAL

PRODUCT SPECIFICATION

Dimensions (HxWxD)	Weight	Max capacity	Colour	Packaging dimensions
730x119x135 mm	3.2 kg	10 kg	black silver	820x190x120 mm



FEATURES

- Telescopic mounting with flexible height adjustment
- Adjustable tilt angle 120°
- 360° full Horizontal adjustment
- Max. capacity 10 kg
- Full cable management

TECHNICAL

PRODUCT SPECIFICATION

Dimensions (HxWxD)	Weight	Max capacity	Colour	Packaging dimensions
1720x119x145 mm	6.5 kg	10 kg	black silver	1000x200x160 mm

CEILING MONITOR MOUNTS





19"-27" Monitor Adjustable Ceiling Mount

SV35

FEATURES

- Telescopic mounting - with flexible height adjustment
- Adjustable tilt angle 120°
- 360° full Horizontal adjustment
- Max. capacity 20 kg

TECHNICAL

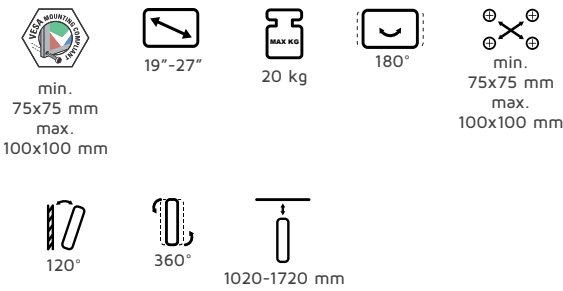

CEILING MONITOR MOUNTS

PRODUCT SPECIFICATION

Dimensions (HxWxD)	Weight	Max capacity	Colour	Packaging dimensions
1720x119x145 mm	6.7 kg	20 kg	black silver	1000x200x160 mm



19"-27" Dual Monitor Desktop Arm Mount

DM121

MONITOR MOUNTS



FEATURES

- Flexible option of mounting 2 screens
- Articulating aluminum arms with a semi-textured powder coat or anodized finish
- Two options of the installation: through desk and edge of desk
- Easy and simple installation in just 2 steps

TECHNICAL

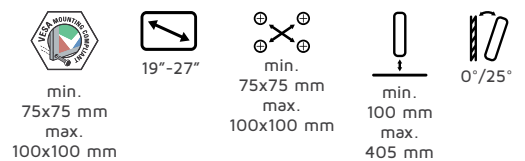

PRODUCT SPECIFICATION

Dimensions (HxWxD)	Weight	Max capacity	Colour	Packaging dimensions
405x125x1300 mm	6,1 kg	20 kg	black silver white	520x270x110 mm



FEATURES

- Adjustable arm length up to 700 mm
- Articulating aluminum arms with a semi-textured powder coat or anodized finish
- Two options of the installation: through desk and edge of desk
- Easy and simple installation in just 2 steps



TECHNICAL



PRODUCT SPECIFICATION

Dimensions (HxWxD)	Weight	Max capacity	Colour	Packaging dimensions
405x125x700 mm	4,2 kg	10 kg	black silver white	480x365x115 mm



19"-27" Dual Monitor Desktop Arm Mount

DM141

FEATURES

- Flexible option of mounting 4 screens
- Articulating aluminum arms with a semi-textured powder coat or anodized finish
- Two options of the installation: through desk and edge of desk
- Easy and simple installation in just 2 steps

TECHNICAL

min. 75x75 mm max. 100x100 mm

19"-27"

min. 75x75 mm max. 100x100 mm

min. 100 mm max. 405 mm

0°/25°

40 kg



MONITOR MOUNTS

PRODUCT SPECIFICATION

Dimensions (HxWxD)	Weight	Max capacity	Colour	Packaging dimensions
705x125x1300 mm	11 kg	40 kg	black silver white	1000x200x150 mm

ACCESSORIES

GDA01 VESA Adapter Plate 200x100

Colour	Packaging dimensions
black grey white	230x125x20 mm



GDA02 VESA Adapter Plate 200x200

Colour	Packaging dimensions
black grey white	225x225x20 mm





CABLE CUBBIES

FEATURES

Multiple Configurations - interchangeable connectors make it possible to adapt to individual needs

Customization - the boxes are available in brushed stainless steel and powder coated to any RAL color

Universal - design of the cable cubbies makes it fits with office space and provides convenient access to the connectors



Cable Cubby for 3 slots

MCB103

FEATURES

- Easy Assembling
- Brushed Finishing
- Tabletop-mounted

*ports are not included



CABLE CUBBIES

PRODUCT SPECIFICATION

Dimensions (HxWxD)	Weight	Colour
238x130x62 mm	0.7 kg	inox RAL Palette



Cable Cubby for 4 slots

MCB104

FEATURES

- Easy Assembling
- Brushed Finishing
- Tabletop-mounted

*ports are not included



PRODUCT SPECIFICATION

Dimensions (HxWxD)	Weight	Colour
285x130x62 mm	0.8 kg	inox RAL Palette



CABLE CUBBIES

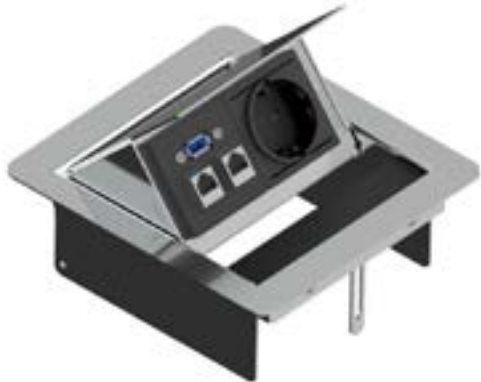

FEATURES

- Easy Assembling
- Brushed Finishing
- Tabletop-mounted

*ports are not included

PRODUCT SPECIFICATION

Dimensions (HxWxD)	Weight	Colour
164x174.5x62 mm	0.8 kg	inox RAL Palette



FEATURES

- Easy Assembling
- Brushed Finishing
- Tabletop-mounted

*ports are not included



PRODUCT SPECIFICATION

Dimensions (HxWxD)	Weight	Colour
216x174.5x62 mm	1 kg	inox RAL Palette



FEATURES

- Easy assembling for 4 slots
 - Brushed Finishing
 - Tabletop-mounted
- *ports are not included

PRODUCT SPECIFICATION

Dimensions (HxWxD)	Weight	Colour
277x174.5x62 mm	1.1 kg	inox RAL Palette



FEATURES

- Easy Assembling
- Brushed Finishing
- Tabletop-mounted

*ports are not included

PRODUCT SPECIFICATION

Dimensions (HxWxD)	Weight	Colour
277x174.5x62 mm	1.3 kg	inox RAL Palette



POS MOUNTS

Design - ergonomically design for operator and customer

Universal - compatible with all manufacturer payment terminals



Double arm mount

POS01

FEATURES

- Screen mount compatible with VESA standards
- Internal space for wires and cables
- Arm & head rotation angle 360°
- One arm dedicated for the pad, second one for the screen mount

TECHNICAL



18°/18°



90°/90°



15 kg



POS MOUNT

PRODUCT SPECIFICATION

Dimensions (HxWxD)	Weight	Colour
388x75x75 mm	1 kg	black silver white



Single arm mount

POS02

POS MOUNT



FEATURES

- Modern design that fits any interior design
- Compact design that minimize space
- Features solid swivel head
- Dedicated internal space for wires and cables

TECHNICAL



360°



50°



5 kg

PRODUCT SPECIFICATION

Dimensions (HxWxD)	Weight	Colour
175x660x93 mm	0.5 kg	black silver white

FEATURES

- Screen mount compatible with VESA standards
- Internal space for wires and cables
- Arm & head rotation angle 360°
- One arm dedicated for the pad, second one for the screen mount



PRODUCT SPECIFICATION

Dimensions (HxWxD)	Weight	Colour
388x75x75 mm	5 kg	black silver white

TECHNICAL





FEATURES

- Screen mount compatible with VESA standards
- Internal space for wires and cables
- Arm & head rotation angle 360°
- One arm dedicated for the pad, second one for the screen mount

TECHNICAL



18°/18°



90°/90°



15 kg



PRODUCT SPECIFICATION

Dimensions (HxWxD)	Weight	Colour
500x380x200 mm	3.5 kg	black silver white



TABLETS

FEATURES

One box - ready to use solution including mount, universal tablet bracket and accessories

Universal - complete range including iPad and universal brackets for key manufacturers

Modern Design - Slim mount casing with rounded corners for sleek look and touch

Security - lockable options and featuring security screws for safety in public areas



Tablet Mount

IPM01

FEATURES

- Flexible mounting options
- Includes security screw theft-protection
- Low profile design
- Easy and simple installation in just 3 steps

TECHNICAL



7"-10"



TABLET ENCLOSURES

PRODUCT SPECIFICATION

Dimensions (HxWxD)	Weight	Max capacity	Colour	Packaging dimensions
270x250x30 mm	0,8 kg	5 kg	black silver white	290x270x50 mm



Tablet Enclosure

ITE03

FEATURES

- Flexible mounting options
- Includes anti-theft system
- Customization options
- Low profile design
- Easy and simple installation in just 3 steps

TECHNICAL



7"-21"

TABLET ENCLOSURES



PRODUCT SPECIFICATION

Dimensions (HxWxD)	Weight	Max capacity	Colour	Packaging dimensions
custom	4 kg	10 kg	RAL Palette	custom



TABLET ENCLOSURES



FEATURES

- Solid steel design
- Full internal cable management
- Heavy stable base
- Adjustable tilt angle
- Customization options

TECHNICAL



10°-21°

PRODUCT SPECIFICATION

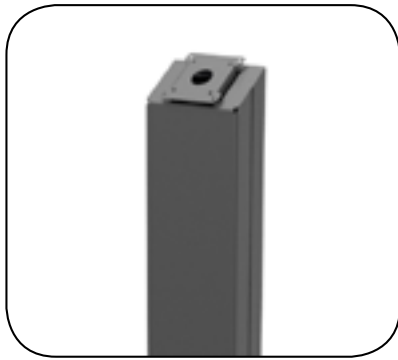

Product	Image	Adjustment range	Max. capacity	VESA	Weight	Dimensions (HxWxD)
ITSV03		29°/44°	8 kg	min. 75x75 max. 100x100	19 kg	400x450x1030 mm
ITSV03L		29°/44°	8 kg	min. 75x75 max. 100x100	19 kg	400x450x1030 mm
ITSV03P		29°/44°	8 kg	min. 75x75 max. 100x100	19 kg	400x450x1030 mm

TABLET STANDS



FEATURES

- Low profile design
- Heavy stable base
- Customization options
- Includes security screw theft-protection

PRODUCT SPECIFICATION

Dimensions (HxWxD)	Weight	Max capacity	Colour	Packaging dimensions
350x350x1050 mm	12 kg	10 kg	RAL Palette	450x450x1150 mm

TECHNICAL





TABLET STANDS



FEATURES

- Modern Design, slim mount casing
- Heavy stable base
- Customization options
- Includes security screw theft-protection

TECHNICAL



10 kg



10°

PRODUCT SPECIFICATION

Dimensions (HxWxD)	Weight	Max capacity	Colour	Packaging dimensions
250x300x1220 mm	14 kg	10 kg	RAL Palette	350x400x1320 mm



FEATURES

- Universal range of Vesa mounts and adapter included
- Adjustable tilt angle from 0° to 45°
- Heavy stable base with optional mounting direct to floor
- Full internal cable management
- Tubular chrome pole luxury finish

TECHNICAL



min. 75x75
max.
100x100 mm



45°



5 kg



7"-21"



TABLET STANDS

PRODUCT SPECIFICATION

Dimensions (HxWxD)	Weight	Max capacity	Colour	Packaging dimensions
300x300x1090 mm	9 kg	5 kg	black	400x400x1190 mm



FEATURES

- Universal range of Vesa mounts and adapter included
- Full internal cable management
- Heavy stable base
- Adjustable tilt angle
- Customization options

TECHNICAL



10°-21°



PRODUCT SPECIFICATION



Product	Image	Adjustment range	Max. capacity	VESA	Weight	Dimensions (HxWxD)
ITSV02		29°/44°	5 kg	75x75 mm	15 kg	350x350x1030 mm
ITSV02L		29°/44°	5 kg	75x75 mm	15 kg	350x350x1030 mm



INFOKIOSKS AND ENCLOSURES

FEATURES

Security - including security screws and door locks for theft protection

Easy Maintenance - full screen installation and electrical wiring access included

Universal - complete range of indoor and outdoor options including to IP65

Customization - full service options including designs, RAL colour, Laser cutting and Vinyl Wrap



19"-27" Indoor Touch Kiosk

IDS02 Series

FEATURES

- Kiosk for 19"-27" LCD screen
- Solid steel design
- Thermal receipt printer
- Easy and simple maintenance
- Speakers
- Full cable management

TECHNICAL



19"-27"



SCREEN ENCLOSURES

PRODUCT SPECIFICATION

Dimensions (HxWxD)	Weight	Colour	Packaging dimensions
1340x500x380 mm	50	RAL Palette	1400x600x420 mm



32"-65" Public Display Kiosk

IDS06 Series

SCREEN ENCLOSURES



FEATURES

- Kiosk for 32"-65" LCD screen
- Solid steel design
- Tamper-proof glass
- Easy maintenance
- Customization possibilities

TECHNICAL



32"-65"

PRODUCT SPECIFICATION

Dimensions (HxWxD)	Weight	Colour	Packaging dimensions
1980x950x388,5	75 kg	RAL Palette	2100x970x415 mm

FEATURES

- Solid steel design
- Tamper-proof glass
- Internal ventilation system
- Easy and simple maintenance
- Customization possibilities

PRODUCT SPECIFICATION

Dimensions (HxWxD)	Weight	Colour	Packaging dimensions
2210x1235x295 mm	100 kg	RAL Palette	2250x1250x310 mm

TECHNICAL



42"-65"





FEATURES

- Modern Design
- Solid steel design
- Tamper-proof glass
- Internal ventilation system
- Easy and simple maintenance
- Customization possibilities

PRODUCT SPECIFICATION

Dimensions (HxWxD)	Weight	Colour	Packaging dimensions
500x1100x2300 mm	110 kg	RAL Palette	600x1200x2400 mm

TECHNICAL



40"-65"

VX200

40"-65" Public Display Stand



SCREEN ENCLOSURES



FEATURES

- Modern Design
- Solid steel design
- Tamper-proof glass
- Internal ventilation system
- Easy and simple maintenance
- Customization possibilities

TECHNICAL



40"-65"

PRODUCT SPECIFICATION

Dimensions (HxWxD)	Weight	Colour	Packaging dimensions
500x930x2300 mm	110 kg	RAL Palette	600x1030x2400 mm

VX300

40"-65" Public Display Stand



FEATURES

- Modern Design
- Solid steel design
- Tamper-proof glass
- Internal ventilation system
- Easy and simple maintenance
- Customization possibilities

TECHNICAL



40"-65"



SCREEN ENCLOSURES

PRODUCT SPECIFICATION

Dimensions (HxWxD)	Weight	Colour	Packaging dimensions
600x1020x2325 mm	120 kg	RAL Palette	700x1120x2425 mm



40"-47" Public Display Floor Stand

VX400

FEATURES

- Modern Design
- Solid steel design
- Easy and simple maintenance
- Customization possibilities

TECHNICAL



40"-47"



SCREEN ENCLOSURES

PRODUCT SPECIFICATION

Dimensions (HxWxD)	Weight	Colour	Packaging dimensions
600x1150x1400 mm	100 kg	RAL Palette	700x1250x1500 mm



32"-65" LCD/LED Indoor Enclosure

IEN01 Series

SCREEN ENCLOSURES



FEATURES

- Modern design
- Easy and Simple maintenance
- Glass front
- Customization possibilities

TECHNICAL



32"-65"

PRODUCT SPECIFICATION

Dimensions (HxWxD)	Weight	Colour	Packaging dimensions
1200x840x183 mm	60 kg	RAL palette	2250x1250x310 mm



FEATURES

- Designed for outdoors
- Kiosk have security locks that allow doors open only for authorized persons
- Can be produced in painted steel or stainless steel
- Pre-assembled to simplify installation of entire solution
- Anti-vandal glass
- Easy and Simple maintenance

PRODUCT SPECIFICATION

Dimensions (HxWxD)	Weight	Colour	Packaging dimensions
2100x1100x250 mm - 40"- 55" 2400x1250x250 mm - 55"- 65"	450 kg - 40"-55" 500 kg - 55"-65"	RAL Palette	2200x1200x350 mm 2500x1350x350 mm

TECHNICAL



40"-65"

QUICK REFERENCE INDEX

PROJECTOR MOUNTS

PM1 - Universal Projector Ceiling Mount (3 fixing points)	20
PM2 - Universal Projector Ceiling Mount (4 fixing points)	20
PM3 - Universal Projector Ceiling Mount (3 fixing points)	21
PM4 - Universal Projector Ceiling Mount	21
PM8 Series - Universal Projector Ceiling Mount	22
WPM1 - Universal Projector Wall Mount (3 fixing points)	23
PT03 - Projector Trolley	23
PMV Series - Projector Ceiling Mount	24
WPMV Series - Wall Projector Mount	25

ACCESSORIES

PMARM100 - Decorative finishing ring for projectors	26
---	----

TROLLEYS AND STANDS

STD16 - Display Stand	28
STD17D - 37"-60" Stand and Trolley for 2 displays	28
STD17 - 37"-60" Display Stand and Trolley	29
STD25 - 42"-50" Display Stand with Enclosure	30
TR1 - 42"-70" Flat Screen Trolley	30
STD01 - 32"-55" Display Stand	31
STD04 - 19"-32" Display Stand	32
TRV100 - Video Conferencing Trolley	33
TRV200 - Video Conferencing Trolley	33
TRV300 - Video Conferencing Trolley for 2 displays	34
TR3 - 37"-60" Dual Display AV Trolley	35
TR51 - 37"-60" Display AV Trolley	35
TR5 - 32"-60" Flat Screen AV Trolley	36
TR7 - 37"-60" Flat Screen AV Trolley	37
TR8 - 37"-60" Low Level Flat Screen Trolley	37
SV53 - 19"-27" Universal Adjustable Trolley with PC Mount	38
TR14 - 40"-47" Dual Flat Screen AV Trolley	38
TR18 - 60"-95" Flat Screen AV Trolley	39
TR20 - 50"-60" Dual Flat Screen AV Trolley	39
ETR Series - ETR Series Electric height-adjustable AV Trolleys	40
ETRE Series - ETRE Series Full Electric height-adjustable AV Trolleys	40
VCTX Series - Video Conferencing Trolley with height adjustment	41
VCTR260 - 50"-60" Video Conferencing Trolley for 2 Screens	41
VCTX255 - Video Conferencing Trolley for 2 Screens	42
VCTR195 - 65"-95" Video Conferencing Trolley	43

ACCESSORIES

CH1 - Video Conferencing Camera Shelf for TR1/TR2/TR3 Trolley	44
CH3 - Video Conferencing Camera Holder for LWB, PWB, TWB	44
CH4 - Video Conferencing Camera Holder for 40"-55" displays	44
CH5 - Video Conferencing Camera Holder for 55" displays	44
RH1 - Rotating adapter for TR1/TR3	44
TRS1 - Glass shelf for TR1/TR3 trolleys	44
TRS2 - Glass shelf with handle for TR1/TR3 trolleys	44
TRS4 - Glass shelf with handle TR5/TR6 trolleys	45
TRSM100 - Metal shelf for TR5/TR6 trolleys	45
TRSM1 - Metal shelf for TR14/TR18/TR20	45
TRSM300 - AV shelf for LWB/PWB/TWB Series	45
TRSM400 - Soundbar bracket for LWB/PWB/TWB Series	45
RF1 (4 pcs) - Rubber feet (4x)	45

VIDEO WALLS

VWPOP Landscape Series - Universal Video Wall Mounts	49
VWFS Landscape Series - Full Service Universal Video Wall Mounts	50
VWFX Landscape Series - Fixed Universal Video Wall Mounts	51
VWPOP Portrait Series - Universal Pop-Out Video Wall Mounts	53
VWFS Portrait Series - Full Service Universal Video Wall Mounts	54
VWFX Portrait Series - Fixed Universal Video Wall Mounts	55
VWW2255POP-L - Video Wall pop-out for 4 screens 50"-55", Landscape	56
VWCA Landscape Series - Ceiling Video Walls	57
VWTA Landscape Series - Trolley Video Walls	58
VWSA Landscape Series - Video Wall Stands	60
VWFCA Landscape Series - Video Wall Ceiling-Floor Mounted	61
VWCA Portrait Series - Ceiling Video Walls	62
VWTA Portrait Series - Trolley Video Walls	63
VWSA Portrait Series - Video Wall Stands	64
VWFCA Portrait Series - Video Wall Ceiling-Floor Mounted	65
VWLT100 - Mobile LED Mounting System	66
VWLCF100 - Floor-Ceiling LED Mounting System	66
VWLC100 - Ceiling LED Mounting System	67
VWLS100 - Stand LED Mounting System	67
VWLW100 - Pop-Out Led Video Wall Mounting System	68
VWLWE100 - Electric Pop-Out Led Video Wall Mounting System	68

FLAT PANEL WALL MOUNTS

PWS2 - 32"-50" Swing Arm Wall Mount	70
VSM651 - 10"-29" Swing Arm Wall Mount	71
VSM652 - 30"-47" Swing Arm Wall Mount	71
VSM653 - 30"-47" Swing Arm Wall Mount	72
VSM654 - 37"-65" Swing Arm Wall Mount	73
RPWS1 - 42"-70" Heavy Duty Swing Arm Wall Mount	73
RMSA1 - 42"-90" Heavy Duty Swing Arm Wall Mount	74
EWB100 - 26"-40" Fixed Wall Mount	75
EWB200 - 40"-65" Fixed Wall Mount	75
LWB1 - 26"-42" Fixed Wall Mount	76
LWB3 - 26"-40" Portrait Wall Mount	76
PWB1 - 42"-55" Fixed Wall Mount	77
PWB3 - 42"-60" Portrait Wall Mount	77
TWB1 - 65"-75" Fixed Wall Mount	78
TWB3 - 65"-75" Portrait Wall Mount	78
XWB1 - 80"-95" Fixed Wall Mount	79
XWB3 - 80"-95" Portrait Wall Mount	79
EWB250 - 40"-65" Tilt Wall Mount	80
LWB2 - 26"-40" Tilt Wall Mount	80
PWB2 - 42"-60" Tilt Wall Mount	81
TWB2 - 60"-75" Tilt Wall Mount	82
CMLS2 - 32"-47" Tilt Wall Mount	82
CMS21 - 37"-65" Adjustable Ceiling Mount	83
CMS1 - 32"-65" LCD Ceiling Mount	84
CMS2 - 32"-65" Adjustable Ceiling Mount	84
CMS3 - 32"-65" Fixed Ceiling Mount	85
MSV1 - 32"-46" Screen Desk Mount	85
MSV2 - 32"-46" Screen Desk Mount	86

ACCESSORIES

CMARM60 - Decorative finishing ring for ceiling mounts	86
--	----

QUICK REFERENCE INDEX

MENU BOARDS

MBV Series - Menu Board for 42"-57" Screens, Landscape	88
MBV Series - Menu Board for 42"-57" Screens, Portrait	89
MBV Series - Menu Board for 42"-57" Back-to-back Screens, Landscape	90
MBV Series - Menu Board for 42"-55" Back-to-back Screens, Portrait	91
MBV155W-L - 42"-55" Menu Board for 1 screen, multiscreens configuration wall mount, Landscape	92
MBV455Q-L - 42"-55" Ceiling Menu Board for 4 screens, Landscape	92
MBV355T-L - 42"-55" Ceiling Menu Board for 3 screens, triangle, Landscape	93
MBV455BBS-L - 42"-55" Ceiling Menu board for 4 screens, back-to-back, Landscape	94

MONITOR MOUNTS

GD22 - 19"-27" Monitor Fixed Wall Mount	96
GD01 - 19"-27" Monitor Swing Arm Wall Mount	96
GD02 - 19"-27" Monitor Swing Arm Wall Mount	97
GD03 - 19"-27" Monitor Wall Mount	97
GD04 - 19"-27" Monitor Fixed Wall Mount	98
GD20 - 19"-27" Monitor Swing Arm Wall Mount	99
GD24 - 19"-27" Monitor Multi Purpose Mount	99
GD18 - 19"-27" Monitor Swing Arm Wall Mount	100
GD26 - 19"-27" Monitor Swing Arm Wall Mount	101
SV01 - 19"-27" Monitor Desk Mount	101
SV03 - 19"-27" Desk Mount	102
SV29 - 19"-27" Slim Pole Desk Mount	102
SV04 - 19"-27" Desk Mount with Swing Arm	103
SV30 - 19"-27" Slim Pole Desk Mount	104
MSA02 - 19"-27" Swing Arm Wall Mount	104
MSA01 - 19"-27" Adjustable Monitor Ceiling Mount	105
SV05 - 19"-27" Desk Mount for 2 Screens	106
SV06 - 19"-27" Swing Arm Desk Mount for 2 Screens	106
SV07 - 19"-27" Swing Arm Desk Mount for 4 Screens	107
SV08 - 19"-27" Dual Monitor Desk Mount	108
SV10 - 19"-27" Triple Monitor Desk Mount	108
SV11 - 19"-27" Triple Monitor Desk Mount	109
SV16 - 19"-27" Desk Mount for 6 Screens	109
SV17 - 19"-27" Curved Desk Mount for 6 Screens	110
USM1 - 19"-27" Under Shelf Monitor Mount	110
SV31 - 19"-27" Monitor Ceiling Mount	111
SV34 - 19"-27" Monitor Adjustable Ceiling Mount	111
SV35 - 19"-27" Monitor Adjustable Ceiling Mount	112
DM121 - 19"-27" Dual Monitor Desktop Arm Mount	112
DM101 - 19"-27" Dual Monitor Desktop Arm Mount	113
DM141 - 19"-27" Dual Monitor Desktop Arm Mount	114

ACCESSORIES

GDA01 - VESA Adapter Plate 200x100	114
GDA02 - VESA Adapter Plate 200x100	114

CABLE CUBBIES

MCB103 - Cable Cubby for 3 slots	116
MCB104 - Cable Cubby for 4 slots	116
MCB202 - Tilt Cable Cubby for 2 slots	117
MCB203 - Tilt Cable Cubby for 3 slots	117
MCB204 - Tilt Cable Cubby for 4 slots	118
MCB205 - Tilt Cable Cubby for 5 slots	119

POS MOUNT

POS01 - Double arm mount	122
POS02 - Single arm mount	122
POS03 - Double arm mount	123
POS07 - Double arm mount	124

TABLETS

IPM01 - Tablet Mount.....	126
ITE03 - Tablet Enclosure	126
ITSV03 Series - ITSV Series Tablet Stands with VESA Adapter	127
ITS08 - Indoor Tablet Stand	128
ITS07 - Indoor Tablet Stand	129
ITSV01 - ITSV Series Tablet Stands with VESA Adapter	129
ITSV02 - ITSV Series Tablet Stands with VESA Adapter	130

INFOKIOSKS

IDS02 Series - 19"-27" Indoor Touch Kiosk	132
IDS06 Series - 32"-65" Public Display Kiosk	132
IDS07 Series - 42"- 65" Public Display Stand	133
VX100 - 40"-65" Public Display Stand	134
VX200 - 40"-65" Public Display Stand	135
VX300 - 40"-65" Public Display Stand	135
VX400 - 40"-47" Public Display Floor Stand	136
IEN01 Series - 32"-65"LCD/LED Indoor Enclosure	136
ODX100 - 40" - 65" Outdoor Kiosk Enclosure	137

EDBAK Ltd.
Piotrowice 186
23-107 Strzyżewice
Poland
Tel.: +48 81 562 81 19
Fax: +48 81 562 82 90
www.edbakproav.com
sales@edbak.com

